



CHAPTER 4

FITTINGS

ФИТИНГИ

PRESS FITTINGS - RACCORDS À SERTIR - ПРЕСС - ФИТИНГИ	84
PUSH FITTINGS - RACCORDS RAPIDES - ФИТИНГИ БЫСТРОГО КРЕПЕЖА (ПУШ-ФИТИНГИ)	90
FITTINGS FOR MULTILAYER AND SYNTHETIC PIPE - RACCORDS POUR TUBE PLASTIQUE ET MULTICOUCHES - ФИТИНГИ	92
ADAPTORS FOR MULTILAYER AND SYNTHETIC PIPE - ADAPTATEUR POUR TUBE PLASTIQUE ET MULTICOUCHES ПЕРЕХОДНИКИ ДЛЯ ПЛАСТИКОВЫХ И МНОГОСЛОЙНЫХ ТРУБ	95
FITTINGS FOR ADAPTERS - RACCORDS POUR ADAPTATEURS - ПЕРЕХОДНИКИ	96
ADAPTORS FOR COPPER TUBE - ADAPTATEUR POUR TUBE CUIVRE - ПЕРЕХОДНИКИ ДЛЯ МЕДНЫХ ТРУБ	98
FITTINGS FOR COPPER TUBE - RACCORDS POUR TUBE CUIVRE - ФИТИНГИ ДЛЯ МЕДНЫХ ТРУБ	99
FITTINGS IRON-COPPER - RACCORDS FILET UNIVERSEL - CUIVRE - ФИТИНГИ ДЛЯ СОЕДИНЕНИЯ СТАЛЬНЫХ ТРУБ С МЕДНЫМИ	102
FITTINGS FOR IRON TUBE - RACCORDS AVEC FILET UNIVERSEL - ФИТИНГИ ДЛЯ СТАЛЬНЫХ ТРУБ	103
FITTINGS WITH METAL SLEEVE - RACCORDS AVEC BICÔNE MÉTALLIQUE - ФИТИНГИ С МЕТАЛЛИЧЕСКИМ СУХАРЕМ	104

R996T



R999



PRESS FITTINGS

RACCORDS À SERTIR

ПРЕСС - ФИТИНГИ

R996



R978



RP102

Straight fitting, for GIACOTHERM, GIACOFLEX and multilayer pipes and polybutylene pipes.

Nipple à sertir pour GIACOTHERM, GIACOFLEX PB et multicouche.

Прямой фитинг для труб GIACOTHERM, GIACOFLEX, многослойных и полибутиленовых.



Technical communication
0196EN-0196RF

PRODUCT CODE	SIZE	■	□
RP102X012	14x2	10	-
RP102X003	16x2*	10	-
RP102X004	16x2,2	10	-
RP102X013	17x17	10	-
RP102X005	18x2	10	-
RP102X007	20x2*	10	-
RP102X008	20x2,5	10	-
RP102X009	26x3*	5	-
RP102X011	32x3*	5	-
RP102Y014	40x3,5	2	-
RP102Y015	50x4	2	-
RP102Y016	63x4,5	2	-

Adaptors with C.S.T.B. approval

NOTES

Use "TH" profile up to \varnothing 32 mm and "U" profile for \varnothing 40, 50, 63 mm.

Utilisez le profil "TH" à profil \varnothing 32 mm et "U" pour \varnothing 40, 50, 63 mm.

Использовать профиль "TH" до \varnothing 32 мм, профиль "U" на \varnothing 40, 50, 63 мм.

CERTIFICATION AND SYMBOLS



RP107

Male straight fitting, for GIACOTHERM GIACOFLEX and multilayer pipes and polybutylene pipes.

Raccord mâle à sertir pour GIACOTHERM, GIACOFLEX PB et multicouche.

Прямой фитинг для труб GIACOTHERM, GIACOFLEX, многослойных и полибутиленовых.



Technical communication
0196EN-0196RF

PRODUCT CODE	SIZE	■	□
RP107X021	3/8" x(14x2)	10	-
RP107X023	3/8" x(16x2)	10	-
RP107X031	1/2" x(14x2)	10	-
RP107X033	1/2" x(16x2)*	10	-
RP107X034	1/2" x(16x2,2)	10	-
RP107X035	1/2" x(18x2)	10	-
RP107X037	1/2" x(20x2)*	10	-
RP107X038	1/2" x(20x2,5)	10	-
RP107X043	3/4" x(16x2)*	5	-
RP107X047	3/4" x(20x2)*	5	-
RP107X049	3/4" x(26x3)*	5	-
RP107X059	1" x(32x3)*	5	-
RP107Y066	11/4 x(40x3,5)	2	-
RP107Y077	11/2 x(50x4)	2	-
RP107Y088	2 x(63x4,5)	2	-

Adaptors with C.S.T.B. approval

NOTES

Use "TH" profile up to \varnothing 32 mm and "U" profile for \varnothing 40, 50, 63 mm.

Utilisez le profil "TH" à profil \varnothing 32 mm et "U" pour \varnothing 40, 50, 63 mm.

Использовать профиль "TH" до \varnothing 32 мм, профиль "U" на \varnothing 40, 50, 63 мм.

CERTIFICATION AND SYMBOLS



RP103

Reducing straight fitting for GIACOTHERM, GIACOFLEX and multilayer and polybutylene pipes.

Raccord réduit à sertir pour GIACOTHERM, GIACOFLEX PB et multicouche.

Прямой фитинг-переходник для труб GIACOTHERM, GIACOFLEX, многослойных и полибутиленовых.



Technical communication
0196EN-0196RF

PRODUCT CODE	SIZE	■	□
RP103X010	(20x2)x(16x2)*	10	-
RP103X012	(20x2,5)x(16x2)	10	-
RP103X018	(26x3)x(20x2)*	10	-
RP103X019	(26x3)x(20x2,5)	5	-
RP103X022	(32x3)x(26x3)*	5	-
RP103Y064	40x3,5x26x3,0	2	-
RP103Y065	40x3,5x32x3,0	2	-
RP103Y075	50x4x32x3,0	2	-
RP103Y076	50x4x40x3,5	2	-
RP103Y086	63x4,5x40x3,5	2	-
RP103Y087	63x4,5x50x4	2	-

Adaptors with C.S.T.B. approval

NOTES

Use "TH" profile up to \varnothing 32 mm and "U" profile for \varnothing 40, 50, 63 mm.

Utilisez le profil "TH" à profil \varnothing 32 mm et "U" pour \varnothing 40, 50, 63 mm.

Использовать профиль "TH" до \varnothing 32 мм, профиль "U" на \varnothing 40, 50, 63 мм.

CERTIFICATION AND SYMBOLS



RP109

Female straight fitting, female thread, for GIACOTHERM, GIACOFLEX and multilayer pipes.

Raccord femelle à sertir pour GIACOTHERM, GIACOFLEX PB et multicouche.

Прямой фитинг с внутренней резьбой для труб GIACOTHERM, GIACOFLEX и многослойных.



Technical communication
0196EN-0196RF

PRODUCT CODE	SIZE	■	□
RP109X031	1/2" x(14x2)	10	-
RP109X033	1/2" x(16x2)*	10	-
RP109X034	1/2" x(16x2,2)	10	-
RP109X035	1/2" x(18x2)	10	-
RP109X037	1/2" x(20x2)*	10	-
RP109X038	1/2" x(20x2,5)	10	-
RP109X043	3/4" x(16x2)*	5	-
RP109X047	3/4" x(20x2)*	5	-
RP109X049	3/4" x(26x3)*	5	-
RP109X059	1" x(32x3)*	5	-
RP109Y060	1 x(40x3,5)	2	-
RP109Y066	11/4 x(40x3,5)	2	-
RP109Y075	11/4 x(50x4)	2	-
RP109Y077	11/2 x(50x4)	2	-
RP109Y088	2 x(63x4,5)	2	-

Adaptors with C.S.T.B. approval

NOTES

Use "TH" profile up to \varnothing 32 mm and "U" profile for \varnothing 40, 50, 63 mm.

Utilisez le profil "TH" à profil \varnothing 32 mm et "U" pour \varnothing 40, 50, 63 mm.

Использовать профиль "TH" до \varnothing 32 мм, профиль "U" на \varnothing 40, 50, 63 мм.

CERTIFICATION AND SYMBOLS



RP122

90° elbow, female thread, for GIACOTHERM, GIACOFLEX and multilayer pipes.



Coude égal à sertir pour GIACOTHERM, GIACOFLEX PB et multicouche.

Коленчатый фитинг 90° для труб GIACOTHERM, GIACOFLEX и многослойных.

PRODUCT CODE	SIZE	■	□
RP122X012	14x2	10	-
RP122X003	16x2*	10	-
RP122X004	16x2,2	10	-
RP122X005	18x2	10	-
RP122X007	20x2*	10	-
RP122X008	20x2,5	10	-
RP122X009	26x3*	5	-
RP122X011	32x2*	5	-
RP122Y013	40x3,5	2	-
RP122Y014	50x4	2	-
RP122Y015	63x4,5	2	-

Adaptors with C.S.T.B. approval

NOTES

Use "TH" profile up to ø 32 mm and "U" profile for ø 40, 50, 63 mm.

Utilisez le profil "TH" à profil ø 32 mm et "U" pour ø 40, 50, 63 mm.

Использовать профиль "TH" до ø 32 мм, профиль "U" на ø 40, 50, 63 мм.

CERTIFICATION AND SYMBOLS

Technical communication
0196EN-0196RF

RP129

90° elbow, female thread, for GIACOTHERM, GIACOFLEX and multilayer pipes.



Coude femelle à sertir pour GIACOTHERM, GIACOFLEX PB et multicouche.

Коленчатый фитинг 90° с внутренней резьбой для труб GIACOTHERM, GIACOFLEX и многослойных.

PRODUCT CODE	SIZE	■	□
RP129X031	1/2"x(14x2)	10	-
RP129X033	1/2"x(16x2)*	10	-
RP129X034	1/2"x(16x2,2)	10	-
RP129X035	1/2"x(18x2)	10	-
RP129X037	1/2"x(20x2)*	10	-
RP129X038	1/2"x(20x2,5)	10	-
RP129X043	3/4"x(16x2)*	10	-
RP129X047	3/4"x(20x2)*	10	-
RP129X049	3/4"x(26x3)*	5	-
RP129X059	1"x(32x3)*	5	-
RP129Y066	1 1/4 x(40x3,5)	2	-
RP129Y077	1 1/2 x(50x4)	2	-
RP129Y088	2 x(63x4,5)	2	-

Adaptors with C.S.T.B. approval

NOTES

Use "TH" profile up to ø 32 mm and "U" profile for ø 40, 50, 63 mm.

Utilisez le profil "TH" à profil ø 32 mm et "U" pour ø 40, 50, 63 mm.

Использовать профиль "TH" до ø 32 мм, профиль "U" на ø 40, 50, 63 мм.

CERTIFICATION AND SYMBOLS

Technical communication
0196EN-0196RF

RP127

90° elbow male for GIACOTHERM GIACOFLEX and multilayer pipes.



Coude mâle à sertir pour GIACOTHERM, GIACOFLEX PB et multicouche.

Коленчатый фитинг 90° с наружной резьбой для труб GIACOTHERM, GIACOFLEX и многослойных.

PRODUCT CODE	SIZE	■	□
RP127X031	1/2"x(14x2)	10	-
RP127X033	1/2"x(16x2)*	10	-
RP127X034	1/2"x(16x2,2)	10	-
RP127X035	1/2"x(18x2)	10	-
RP127X037	1/2"x(20x2)*	10	-
RP127X038	1/2"x(20x2,5)	10	-
RP127X043	3/4"x(16x2)*	10	-
RP127X047	3/4"x(20x2)*	10	-
RP127X049	3/4"x(26x3)*	10	-
RP127Y066	1 1/4 x(40x3,5)	2	-
RP127Y077	1 1/2 x(50x4)	2	-
RP127Y088	2 x(63x4,5)	2	-

Adaptors with C.S.T.B. approval

NOTES

Use "TH" profile up to ø 32 mm and "U" profile for ø 40, 50, 63 mm.

Utilisez le profil "TH" à profil ø 32 mm et "U" pour ø 40, 50, 63 mm.

Использовать профиль "TH" до ø 32 мм, профиль "U" на ø 40, 50, 63 мм.

CERTIFICATION AND SYMBOLS

Technical communication
0196EN-0196RF

RP139

90° elbow with wall bracket female iron thread and press fitting connection for GIACOTHERM GIACOFLEX multilayer and polybutylene pipes.



Sortie de cloison à sertir pour GIACOTHERM, GIACOFLEX PB et multicouche.

Коленчатый фитинг 90° с кронштейном и внутренней резьбой для труб GIACOTHERM, GIACOFLEX многослойных и полибутиленовых.

PRODUCT CODE	SIZE	■	□
RP139X031	1/2"x(14x2)	10	-
RP139X033	1/2"x(16x2)*	10	-
RP139X035	1/2"x(18x2)	5	-
RP139X037	1/2"x(20x2)*	5	-
RP139X038	1/2"x(20x2,5)	5	-
RP139X049	3/4"x(26x3)*	5	-

Adaptors with C.S.T.B. approval

NOTES

Use "TH" profile up to ø 32 mm and "U" profile for ø 40, 50, 63 mm.

Utilisez le profil "TH" à profil ø 32 mm et "U" pour ø 40, 50, 63 mm.

Использовать профиль "TH" до ø 32 мм, профиль "U" на ø 40, 50, 63 мм.

CERTIFICATION AND SYMBOLS

Technical communication
0196EN-0196RF

RP144

45° bend for GIACOTHERM GIACOFLEX multilayer and polybutylene pipes.

Raccord à sertir à 45° pour GIACOTHERM, GIACOFLEX PB et multicouche.

Коленчатый фитинг 45° для труб GIACOTHERM, GIACOFLEX многослойных и полибутиленовых.

PRODUCT CODE	SIZE	■	□
RP144X009	26x3*	5	-
RP144X011	32x3*	5	-

Adaptors with C.S.T.B. approval

NOTES

Use "TH" profile up to ø 32 mm and "U" profile for ø 40, 50, 63 mm.

Utilisez le profil "TH" à profil ø 32 mm et "U" pour ø 40, 50, 63 mm.

Использовать профиль "TH" до ø 32 мм, профиль "U" на ø 40, 50, 63 мм.

CERTIFICATION AND SYMBOLS



Technical communication
0196EN-0196RF

RP151

Reducing tee for GIACOTHERM GIACOFLEX multilayer and polybutylene pipes.

Té inégal à sertir pour GIACOTHERM, GIACOFLEX PB et multicouche.

T-образный фитинг-переходник для труб GIACOTHERM, GIACOFLEX многослойных и полибутиленовых.

PRODUCT CODE	SIZE	■	□
RP151X041	(16x2)x(14x2)x(14x2)	10	-
RP151X042	(16x2)x(14x2)x(16x2)	10	-
RP151X045	(16x2)x(20x2)x(16x2)*	10	-
RP151X046	(16x2)x(20x2,5)x(16x2)	10	-
RP151X063	(20x2)x(16x2)x(16x2)*	10	-
RP151X064	(20x2)x(16x2)x(20x2)*	10	-
RP151X065	(20x2)x(20x2)x(16x2)*	10	-
RP151X067	(20x2)x(26x3)x(20x2)*	5	-
RP151X073	(20x2,5)x(16x2)x(16x2)	10	-
RP151X074	(20x2,5)x(16x2)x(20x2,5)	10	-
RP151X075	(20x2,5)x(20x2,5)x(16x2)	10	-
RP151X077	(20x2,5)x(26x3)x(20x2,5)	5	-
RP151X084	(26x3)x(20x2)x(20x2)*	0	-
RP151X085	(26x3)x(16x2)x(26x3)*	5	-
RP151X086	(26x3)x(20x2)x(26x3)*	5	-
RP151X087	(26x3)x(20x2,5)x(20x2,5)	5	-
RP151X088	(26x3)x(20x2,5)x(26x3)	5	-
RP151X089	(26x3)x(26x3)x(20x2)*	5	-
RP151X092	(32x3)x(26x3)x(26x3)*	5	-
RP151X093	(32x3)x(26x3)x(32x3)*	5	-
RP151Y146	(40x3,5)(26x3)(40x3,5)	2	-
RP151Y147	(40x3,5)(32x3)(40x3,5)	2	-
RP151Y148	(40x3,5)(32x3)(32x3)	2	-
RP151Y149	(40x3,5)(40x3,5)(32x3)	2	-
RP151Y157	(50x4)(26x3)(50x4)	2	-
RP151Y158	(50x4)(32x3)(50x4)	2	-
RP151Y159	(50x4)(40x3,5)(50x4)	2	-
RP151Y167	(63x4,5)(32x3)(63x4,5)	2	-
RP151Y168	(63x4,5)(40x3,5)(63x4,5)	2	-
RP151Y169	(63x4,5)(50x4)(63x4,5)	2	-

Adaptors with C.S.T.B. approval

NOTES

Use "TH" profile up to ø 32 mm and "U" profile for ø 40, 50, 63 mm.

Utilisez le profil "TH" à profil ø 32 mm et "U" pour ø 40, 50, 63 mm.

Использовать профиль "TH" до ø 32 мм, профиль "U" на ø 40, 50, 63 мм.

CERTIFICATION AND SYMBOLS



INFO

**RP150**

Tee fitting for GIACOTHERM GIACOFLEX and multilayer pipes.

Té égal à sertir pour GIACOTHERM, GIACOFLEX PB et multicouche.

T-образный фитинг для труб GIACOTHERM, GIACOFLEX и многослойных.

PRODUCT CODE	SIZE	■	□
RP150X002	14x2	10	-
RP150X003	16x2*	10	-
RP150X004	16x2,2	10	-
RP150X005	18x2	10	-
RP150X007	20x2*	10	-
RP150X008	20x2,5	10	-
RP150X009	26x3*	5	-
RP150X011	32x3*	5	-
RP150Y012	40x3,5	2	-
RP150Y013	50x4	2	-
RP150Y014	63x4,5	2	-

Adaptors with C.S.T.B. approval

NOTES

Use "TH" profile up to ø 32 mm and "U" profile for ø 40, 50, 63 mm.

Utilisez le profil "TH" à profil ø 32 mm et "U" pour ø 40, 50, 63 mm.

Использовать профиль "TH" до ø 32 мм, профиль "U" на ø 40, 50, 63 мм.

CERTIFICATION AND SYMBOLS



Technical communication
0196EN-0196RF

RP165

End cap, for GIACOTHERM, GIACOFLEX multilayer and polybutylene pipes.

Bouchon de terminaison, pour tube GIACOTHERM, GIACOFLEX, multicouche et polybutène.

Никелированная заглушка для труб GIACOTHERM, GIACOFLEX многослойных и полибутиленовых.

PRODUCT CODE	SIZE	■	□
RP165X005	20x2	10	-

NOTES

Use "TH" profile up to ø 32 mm and "U" profile for ø 40, 50, 63 mm.

Utilisez le profil "TH" à profil ø 32 mm et "U" pour ø 40, 50, 63 mm.

Использовать профиль "TH" до ø 32 мм, профиль "U" на ø 40, 50, 63 мм.

Technical communication
0196EN-0196RF

RP158

Tee fitting, with copper pipe ø 16, 45° inclined, chrome plated, for GIACOTHERM, GIACOFLEX multilayer pipes.

Sortie de sol à sertir, avec cuivre tube ø 16 chromé, 45° incliné, pour GIACOTHERM, GIACOFLEX PB et multicouche.

T-образный хромированный фитинг с изгибом 45° с медной трубой ø 16 для труб GIACOTHERM, GIACOFLEX многослойных.

Technical communication
0196EN-0196RF

PRODUCT CODE	SIZE	■	□
RP158X034	(16x2)x16x(16x2)*	1	50

Adaptors with C.S.T.B. approval

NOTES

Use "TH" profile up to ø 32 mm and "U" profile for ø 40, 50, 63 mm.

Utilisez le profil "TH" à profil ø 32 mm et "U" pour ø 40, 50, 63 mm.

Использовать профиль "TH" до ø 32 мм, профиль "U" на ø 40, 50, 63 мм.

CERTIFICATION AND SYMBOLS



INFO

Lenght 30 cm.
Longueur 30 cm.
Длина 30 см.

RP153

Tee fitting, for GIACOTHERM, GIACOFLEX and multilayer pipes male thread.

Té égal à sertir avec sortie mâle pour GIACOTHERM, GIACOFLEX PB et multicouche.

T-образный фитинг с наружной резьбой для труб GIACOTHERM, GIACOFLEX и многослойных.



Technical communication
0196EN-0196RF

PRODUCT CODE	SIZE	■	□
RP153X033	(16x2)x1/2"x(16x2)*	10	-
RP153X034	(16x2,2)x1/2"x(16x2,2)	10	-
RP153X035	(18x2)x1/2"x(18x2)	10	-
RP153X037	(20x2)x1/2"x(20x2)*	10	-
RP153Y064	(40x3,5)(11/4M)(40x3,5)	2	-
RP153Y075	(50x4)(11/2M)(50x4)	2	-
RP153Y088	(63x4,5)(2M)(63x4,5)	2	-

Adaptors with C.S.T.B. approval

NOTES

Use "TH" profile up to ø 32 mm and "U" profile for ø 40, 50, 63 mm.

Utilisez le profil "TH" à profil ø 32 mm et "U" pour ø 40, 50, 63 mm.

Использовать профиль "TH" до ø 32 мм, профиль "U" на ø 40, 50, 63 мм.

CERTIFICATION AND SYMBOLS**INFO****RP154**

Tee fitting, for GIACOTHERM GIACOFLEX and multilayer pipes.

Té inégal à sertir, avec sortie femelle, pour GIACOTHERM, GIACOFLEX PB et multicouche

T-образный фитинг для труб GIACOTHERM, GIACOFLEX и многослойных.



Technical communication
0196EN-0196RF

PRODUCT CODE	SIZE	■	□
RP154X033	(16x2)x1/2"x(16x2)*	10	-
RP154X034	(16x2,2)x1/2"x(16x2,2)	10	-
RP154X035	(18x2)x1/2"x(18x2)	10	-
RP154X037	(20x2)x1/2"x(20x2)*	10	-
RP154X038	(20x2,5)x1/2"x(20x2,5)	10	-
RP154X049	(26x3)x3/4"x(26x3)*	5	-
RP154X059	(32x3)x1"x(32x3)*	5	-
RP154Y064	(40x3,5)(11/4F)(40x3,5)	2	-
RP154Y075	(50x4)(11/2F)(50x4)	2	-
RP154Y088	(63x4,5)(2F)(63x4,5)	2	-

Adaptors with C.S.T.B. approval

NOTES

Use "TH" profile up to ø 32 mm and "U" profile for ø 40, 50, 63 mm.

Utilisez le profil "TH" à profil ø 32 mm et "U" pour ø 40, 50, 63 mm.

Использовать профиль "TH" до ø 32 мм, профиль "U" на ø 40, 50, 63 мм.

CERTIFICATION AND SYMBOLS**INFO****RP128**

90° elbow, with copper pipe ø 16 chrome plated, for GIACOTHERM, GIACOFLEX multilayer pipes.

Sortie de sol à sertir, avec cuivre tube ø 16 chromé, pour GIACOTHERM, GIACOFLEX PB et multicouche.

Коленчатый хромированный фитинг 90° с медной трубой ø 16 для труб GIACOTHERM, GIACOFLEX многослойных.



Technical communication
0196EN-0196RF

PRODUCT CODE	SIZE	■	□
RP128X034	(16x2)x16*	1	50

Adaptors with C.S.T.B. approval

NOTES

Use "TH" profile up to ø 32 mm and "U" profile for ø 40, 50, 63 mm.

Utilisez le profil "TH" à profil ø 32 mm et "U" pour ø 40, 50, 63 mm.

Использовать профиль "TH" до ø 32 мм, профиль "U" на ø 40, 50, 63 мм.

CERTIFICATION AND SYMBOLS**INFO**

Lenght 30 cm.

Longueur 30 cm.

Длина 30 см.

RP179E

Straight adaptor, with nut for EUROCONE and press fitting connection, for GIACOTHERM, GIACOFLEX multilayer and polybutylene pipes.

Raccord femelle écrou libre, à sertir, pour Eurocone, pour GIACOTHERM, GIACOFLEX PB et multicouche.

Прямой фитинг-переходник с гайкой для соединения евроконус, для труб GIACOTHERM, GIACOFLEX многослойных и полибутиленовых.



Technical communication
0196EN-0196RF

PRODUCT CODE	SIZE	■	□
RP179X103	3/4"Ex(16x2)*	10	-
RP179X106	3/4"Ex(20x2)*	10	-
RP179X107	3/4"Ex(20x2,5)	10	-

Adaptors with C.S.T.B. approval

NOTES

Use "TH" profile up to ø 32 mm and "U" profile for ø 40, 50, 63 mm.

Utilisez le profil "TH" à profil ø 32 mm et "U" pour ø 40, 50, 63 mm.

Использовать профиль "TH" до ø 32 мм, профиль "U" на ø 40, 50, 63 мм.

CERTIFICATION AND SYMBOLS**RP18**

Straight adaptor, nickel plated with nut for adaptor, press fitting connection for GIACOTHERM, GIACOFLEX multilayer and polybutylene pipes.

Raccord droit 3 pièces à sertir pour GIACOTHERM, GIACOFLEX PB et multicouche.

Прямой фитинг-переходник из 3 частей с внутренней резьбой для труб GIACOTHERM, GIACOFLEX многослойных и полибутиленовых.



Technical communication 0196EN-0196RF

PRODUCT CODE	SIZE	■	□
RP18X033	1/2"x(16x2)*	10	-
RP18X037	1/2"x(20x2)*	10	-
RP18X038	1/2"x(20x2,5)	10	-
RP18X049	3/4"x(26x3)*	5	-

Adaptors with C.S.T.B. approval

NOTES

Use "TH" profile up to ø 32 mm and "U" profile for ø 40, 50, 63 mm.

Utilisez le profil "TH" à profil ø 32 mm et "U" pour ø 40, 50, 63 mm.

Использовать профиль "TH" до ø 32 мм, профиль "U" на ø 40, 50, 63 мм.

CERTIFICATION AND SYMBOLS

RP179SP

Straight adaptor, hexagonal nut and flat washer, press fitting connection for GIACOTHERM, GIACOFLEX multilayer and polybutylene pipes.



Raccord femelle écrou libre à sertir, pour GIACOTHERM, GIACOFLEX PB et multicouche.

Прямой фитинг-переходник с шестиугольной гайкой и плоским кольцом для труб GIACOTHERM, GIACOFLEX многослойных и полибутиленовых.

Technical communication
0196EN-0196RF

PRODUCT CODE	SIZE	□	▣
RP179Y041	3/8"x(14x2)	10	-
RP179Y043	3/8"x(16x2)*	10	-
RP179Y050	1/2"x(14x2)	10	-
RP179Y051	1/2"x(12x1,1)	0	-
RP179Y052	1/2"x(16x1,5)	10	-
RP179Y053	1/2"x(16x2)*	10	-
RP179Y066	3/4"x(20x2)*	10	-
RP179Y069	3/4"x(26x3)*	10	-
RP179Y056	1/2"x20x2	10	360
RP179Y063	3/4"x16x2	10	200

Adaptors with C.S.T.B. approval

NOTES

Use "TH" profile up to ø 32 mm and "U" profile for ø 40, 50, 63 mm.

Utilisez le profil "TH" à profil ø 32 mm et "U" pour ø 40, 50, 63 mm.

Использовать профиль "TH" до ø 32 мм, профиль "U" на ø 40, 50, 63 мм.

CERTIFICATION AND SYMBOLS

**RP179T**

Straight adaptor, nickel plated with nut for adaptor, press fitting connection for GIACOTHERM, GIACOFLEX multilayer and polybutylene pipes.



Adaptateur à sertir pour GIACOTHERM, GIACOFLEX PB et multicouche.

Прямой никелированный фитинг-переходник с накидной гайкой для труб GIACOTHERM, GIACOFLEX многослойных и полибутиленовых.

Technical communication
0196EN-0196RF

PRODUCT CODE	SIZE	□	▣
RP179X020	16x(14x2)	10	-
RP179X021	16x(12x1,1)	10	-
RP179X022	16x(16x1,5)	10	-
RP179X023	16x(16x2)*	10	-
RP179X032	18x(16x1,5)	10	-
RP179X035	18x(18x2)	10	-

Adaptors with C.S.T.B. approval

NOTES

Use "TH" profile up to ø 32 mm and "U" profile for ø 40, 50, 63 mm.

Utilisez le profil "TH" à profil ø 32 mm et "U" pour ø 40, 50, 63 mm.

Использовать профиль "TH" до ø 32 мм, профиль "U" на ø 40, 50, 63 мм.

CERTIFICATION AND SYMBOLS

**RP19**

90° elbow adaptor in 3 pieces, female iron thread, press fitting connection for GIACOTHERM, GIACOFLEX multilayer and polybutylene pipes.

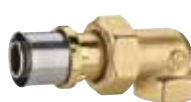

Raccord équerre 3 pièces à sertir pour GIACOTHERM, GIACOFLEX PB et multicouche.

Коленчатый фитинг-переходник 90° из 3 частей с внутренней резьбой для труб GIACOTHERM, GIACOFLEX многослойных и полибутиленовых.

Technical communication
0196EN-0196RF

PRODUCT CODE	SIZE	□	▣
RP19X033	1/2"x(16x2)*	10	-
RP19X037	1/2"x(20x2)*	10	-
RP19X038	1/2"x(20x2,5)	10	-
RP19X049	3/4"x(26x3)*	5	-

Adaptors with C.S.T.B. approval

NOTES

Use "TH" profile up to ø 32 mm and "U" profile for ø 40, 50, 63 mm.

Utilisez le profil "TH" à profil ø 32 mm et "U" pour ø 40, 50, 63 mm.

Использовать профиль "TH" до ø 32 мм, профиль "U" на ø 40, 50, 63 мм.

CERTIFICATION AND SYMBOLS

**RP20**

Straight fitting, in 3 pieces, female iron thread, press fitting connection for GIACOTHERM, GIACOFLEX multilayer and polybutylene pipes.



Raccord 3 pièces à sertir pour GIACOTHERM, GIACOFLEX PB et multicouche.

Прямой фитинг-переходник из 3 частей с внутренней резьбой для труб GIACOTHERM, GIACOFLEX многослойных и полибутиленовых.

Technical communication
0196EN-0196RF

PRODUCT CODE	SIZE	□	▣
RP20X033	16x2	10	-
RP20X077	20x2	10	-
RP20X099	26x3	5	-

Adaptors with C.S.T.B. approval

NOTES

Use "TH" profile up to ø 32 mm and "U" profile for ø 40, 50, 63 mm.

Utilisez le profil "TH" à profil ø 32 mm et "U" pour ø 40, 50, 63 mm.

Использовать профиль "TH" до ø 32 мм, профиль "U" на ø 40, 50, 63 мм.

CERTIFICATION AND SYMBOLS

**RP173**

Stop valve with screw-down shut off and RP connections.



Robinet d'arrêt à clapet et raccord type RP.

Винтовой запорный кран с соединениями под пресс.

Technical communication
0196EN-0196RF

PRODUCT CODE	SIZE	□	▣
RP173Y033	16x6/2	1	50
RP173Y037	20x20/2	1	50

NOTES

Use "TH" profile up to ø 32 mm and "U" profile for ø 40, 50, 63 mm.

Utilisez le profil "TH" à profil ø 32 mm et "U" pour ø 40, 50, 63 mm.

Использовать профиль "TH" до ø 32 мм, профиль "U" на ø 40, 50, 63 мм.

CERTIFICATION AND SYMBOLS



RP200

Kit for press fittings with:
- electric press machine
- three tongs
- metallic cabinet.



Coffret avec pince à sertir 220V et 3 machoires.

Комплект для пресс-фитингов, включает:
- электрический пресс- 3 пары клещей
- металлический чемоданчик.

PRODUCT CODE	SIZE	□	⊞
RP200Y002	16-20-26 mm	1	25

Technical communication
0196EN-0196RF

RP200-1

Kit with battery press tool 12V for press fittings, supplied in case, equipped with battery charger and no.3 pincers.



Les kits de batterie 12V outils de presse pour les raccords, fournis dans une mallette de transport avec chargeur et n° 3 pinces fournies.

Пресс наборы инструментов для прессовых соединений, батарея на 12V, поставляется в кейсе с зарядным устройством и 3 щипцами.

PRODUCT CODE	SIZE	□	⊞
RP200Y022	16-20-26 mm	1	-

Technical communication
0196EN-0196RF

RP201

Kit for press fittings.



Coffret avec pince à sertir 220V, 3 machoires et batterie.

Комплект инструментов для пресс-фитингов.

PRODUCT CODE	SIZE	□	⊞
RP201Y000	-	1	-
RP201Y022	-	1	-

Technical communication
0196EN-0196RF

RP202

Tongs for RP200 press machine.

Machaires pour pince RP200.

Клещи для пресса RP200.

**TH PROFILE**

PRODUCT CODE	SIZE	□	⊞
RP202Y012	12	1	-
RP202Y014	14	1	-
RP202Y016	16	1	-
RP202Y017	17	1	-
RP202Y018	18	1	-
RP202Y020	20	1	-
RP202Y026	26	1	-
RP202Y032	32	1	-
RP202Y040	40 U	1	-

Technical communication
0196EN-0196RF

RP203

Base jaw for RP202 Ø 50-63 mm RP202. "U" profile tongs.

Mâchoire de base pour RP202 Ø 50-63 mm RP202: mâchoire profil "U".

Базовые клещи для вставок RP202 Ø 50-63 мм RP202: профиль "U".



PRODUCT CODE	SIZE	□	⊞
RP203Y103	50-63 NP	1	-



RP202Y150-163

RP204

Roller pipe cutter (up to 40mm)

Coupe-tube.

Роликовый резак для труб (диаметр до 40 мм).



PRODUCT CODE	SIZE	□	⊞
RP204Y001	0-40 mm	1	-

Technical communication
0196EN-0196RF

RP205

Deburring tool for GIACOTHERM, GIACOFLEX and multilayer pipes.

Alésoir pour GIACOTHERM, GIACOFLEX, PB et multicouche.

Инструмент для зачистки труб GIACOTHERM, GIACOFLEX и многослойных.



PRODUCT CODE	SIZE	□	⊞
RP205Y001	0÷20	1	-

Technical communication
0196EN-0196RF

RP208

Steel pipe bending spring

Ressort de cintrage.

Стальная трубогнущая пружина.



PRODUCT CODE	SIZE	□	⊞
RP208Y014	14x2	1	-
RP208Y016	16x2	1	50
RP208Y018	18x2	1	50
RP208Y020	20x2	1	-

Technical communication
0196EN-0196RF

RP209

Calibrator/deburring for multilayer pipes.

Calibreur pour tube multicouche.

Калибратор/очиститель для многослойных труб.



PRODUCT CODE	SIZE	□	⊞
RP209Y001	(14x2)÷(20x3)	1	5
RP209Y002	(26x3)÷(32x3)	1	5
RP209Y003	40x3,5-50x4-63x4,5	1	-

Technical communication
0196EN-0196RF

RP209R

Kit with cutters, deburring machine and gauge for multilayer pipes.

RP209Y007: handle box and TH cutters of 16x2, 20x2 and 26x3mm.

Kit Alésage, ébavureur et calibre, pour tube multicouche.

RP209Y007: mallette avec poignée et fraise TH de 16x2, 20x2 et 26x3

Калибратор/очиститель для многослойных труб. RP209Y007: ящик, рукоятка и фреза TH 16x2, 20x2 и 26x3 мм.



HANDLE

CUTTERS

PRODUCT CODE	SIZE	□	⊞
RP209Y007	16x2÷20x2÷26x3	1	-
RP209Y008	handle	1	-
RP209Y009	box	1	-
RP209Y014	14x2	1	-
RP209Y016	16x2	1	-
RP209Y018	18x2	1	-
RP209Y020	20x2	1	-
RP209Y026	26x2	1	-

R996T

R996

R978

COPPER

PUSH FITTINGS

RACCORDS RAPIDES

ФИТИНГИ БЫСТРОГО КРЕПЕЖА (ПУШ-ФИТИНГИ)

RC102

Push fit straight connector, for GIACOTHERM, GIACOFLEX polybutylene and copper pipes.

Jonction égale rapide pour GIACOTHERM, GIACOFLEX PB et cuivre.

Прямой фитинг для труб GIACOTHERM, GIACOFLEX полибутиленовых и медных.



PRODUCT CODE	SIZE	■	□
RC102X004	12	10	-
RC102X007	16*	10	-
RC102X009	20*	10	-
RC102X010	22	5	-

Technical communication 0135EN

CERTIFICATION AND SYMBOLS



RC127

Push fit 90° elbow adaptor, male thread, for GIACOTHERM GIACOFLEX polybutylene and copper pipes.

Coude mâle rapide pour GIACOTHERM, GIACOFLEX PB et cuivre.

Угловой фитинг 90° с наружной резьбой для труб GIACOTHERM, GIACOFLEX полибутиленовых и медных.



PRODUCT CODE	SIZE	■	□
RC127X014	1/2"x12	10	-
RC127X017	1/2"x16*	10	-
RC127X019	1/2"x20*	10	-
RC127X046	3/4"x22	5	-

Technical communication 0135EN

CERTIFICATION AND SYMBOLS



RC107

Push fit straight adaptor, male thread, for GIACOTHERM GIACOFLEX, polybutylene and copper pipes.

Raccord mâle rapide pour GIACOTHERM, GIACOFLEX PB et cuivre.

Прямой фитинг с наружной резьбой для труб GIACOTHERM, GIACOFLEX полибутиленовых и медных.



PRODUCT CODE	SIZE	■	□
RC107X014	1/2"x12	10	-
RC107X017	1/2"x16*	10	-
RC107X019	1/2"x20*	10	-
RC107X020	1/2"x22	5	-
RC107X046	3/4"x22	5	-

Technical communication 0135EN

CERTIFICATION AND SYMBOLS



RC129

Push fit 90° elbow adaptor, female thread, for GIACOTHERM GIACOFLEX polybutylene and copper pipes.

Coude femelle rapide pour GIACOTHERM, GIACOFLEX PB et cuivre.

Угловой фитинг 90° с внутренней резьбой для труб GIACOTHERM, GIACOFLEX полибутиленовых и медных.



PRODUCT CODE	SIZE	■	□
RC129X014	1/2"x12	10	-
RC129X017	1/2"x16*	10	-
RC129X019	1/2"x20*	10	-
RC129X046	3/4"x22	5	-

Technical communication 0135EN

CERTIFICATION AND SYMBOLS



RC109

Push fit straight adaptor, female thread, for GIACOTHERM GIACOFLEX polybutylene and copper pipes.

Raccord femelle rapide pour GIACOTHERM, GIACOFLEX PB et cuivre.

Прямой фитинг с внутренней резьбой для труб GIACOTHERM GIACOFLEX полибутиленовых и медных.



PRODUCT CODE	SIZE	■	□
RC109X014	1/2"x12	10	-
RC109X017	1/2"x16*	10	-
RC109X019	1/2"x20*	10	-
RC109X046	3/4"x22	5	-

Technical communication 0135EN

CERTIFICATION AND SYMBOLS



RC139

Push fit wall bracket 90° elbow, female thread, for GIACOTHERM, GIACOFLEX polybutylene and copper pipes.

Patère sanitaire avec raccord rapide pour GIACOTHERM, GIACOFLEX PB et cuivre.

Угловой фитинг 90° с кронштейном, с внутренней резьбой для труб GIACOTHERM, GIACOFLEX полибутиленовых и медных.



PRODUCT CODE	SIZE	■	□
RC139X014	1/2"x12	10	-
RC139X017	1/2"x16*	10	-
RC139X019	1/2"x20*	10	-
RC139X046	3/4"x22	5	-

Technical communication 0135EN

CERTIFICATION AND SYMBOLS



RC122

Push fit 90° elbow, for GIACOTHERM, GIACOFLEX polybutylene and copper pipes.

Jonction égale rapide pour GIACOTHERM, GIACOFLEX PB et cuivre.

Угловой фитинг 90° для труб GIACOTHERM, GIACOFLEX полибутиленовых и медных.



PRODUCT CODE	SIZE	■	□
RC122X004	12	10	-
RC122X007	16*	10	-
RC122X009	20*	10	-
RC122X010	22	5	-

Technical communication 0135EN

CERTIFICATION AND SYMBOLS



RC900

Pipe support sleeve for plastic pipe and RC push fittings. *15x1,7 polybutylene pipes R986, R986N, R986B and R986R.

Bague de renfort pour raccord rapide. *15x1,7 tube PB R986, R986N, R986B e R986R.

Укрепляющая втулка для пластиковой трубы и фитингов быстрого крепежа RC. *15x1,7 Трубы полибутиленовые R986, R986N, R986B e R986R.



PRODUCT CODE	SIZE	■	□
RC900Y012	12x1,1	1	50
RC900Y015	15x2*	1	50
RC900Y022	15x2,5	1	50
RC900Y016	16x1,5	1	50
RC900Y017	16x2	1	50
RC900Y018	16x2,2	1	50
RC900Y019	18x2	1	50
RC900Y020	18x2,5	1	50
RC900Y021	20x2/20x1,9	1	50
RC900Y050	22x2	1	50

Technical communication 0135EN

RC151

Push fit reducing tee, for GIACOTHERM, GIACOFLEX polybutylene and copper pipes.



Té inégal avec raccord rapide pour GIACOTHERM, GIACOFLEX PB et cuivre.

T-образный фитинг-переходник для труб GIACOTHERM, GIACOFLEX полибутиленовых и медных.

PRODUCT CODE	SIZE	■	□
RC151X032	16x12x12	10	-
RC151X033	16x12x16*	10	-
RC151X085	22x16x16	5	-
RC151X087	22x16x22	5	-



Technical communication 0135EN

RC153

Push fit adaptor tee, male thread, for GIACOTHERM, GIACOFLEX polybutylene and copper pipes.



Té égal avec attente mâle 1/2" pour GIACOTHERM, GIACOFLEX PB et cuivre.

T-образный фитинг-переходник с наружной резьбой для труб GIACOTHERM, GIACOFLEX полибутиленовых и медных.

PRODUCT CODE	SIZE	■	□
RC153X017	16x1/2"x16*	10	-
RC153X019	20x1/2"x20*	10	-
RC153X046	22x3/4"x22	5	-

CERTIFICATION AND SYMBOLS



Technical communication 0135EN

RC154

Push fit adaptor tee, female thread, for GIACOTHERM, GIACOFLEX polybutylene and copper pipes.



Té égal avec attente femelle 1/2" pour GIACOTHERM, GIACOFLEX PB et cuivre.

T-образный фитинг-переходник с внутренней резьбой для труб GIACOTHERM, GIACOFLEX полибутиленовых и медных.

PRODUCT CODE	SIZE	■	□
RC154X017	16x1/2"x16*	10	-
RC154X019	20x1/2"x20*	10	-
RC154X046	22x3/4"x22	5	-

CERTIFICATION AND SYMBOLS



Technical communication 0135EN

RC179

Chrome plated fitting to change from adaptor base to RC rapid connection.



Raccord chromé pour passer d'une attente base adaptateur au raccord rapide RC.

Хромированный переходник для быстрого соединения RC.

PRODUCT CODE	SIZE	■	□
RC179X016	16x16*	25	250
RC179X026	18x16	25	250
RC179X028	18x20	25	250

CERTIFICATION AND SYMBOLS



Technical communication 0135EN

RC205

Internal-external deburring tool for copper and plastic pipes (no multilayer pipe) from ø 8mm to 35mm.



Ebavureur interne externe pour tube cuivre et plastique (pas multicouche) de ø 8 mm à 35 mm.

Инструмент для снятия фаски внутри/снаружи для медных и пластиковых труб (не многослойных) от ø 8 мм до 35 мм.

PRODUCT CODE	SIZE	■	□
RC205Y001	8-35	1	50

RC573

Push fit wall elbow, female thread, nickel plated, for GIACOTHERM, GIACOFLEX polybutylene and copper pipe.



Patère sanitaire avec raccord rapide pour GIACOTHERM, GIACOFLEX PB et cuivre.

Никелированный коленчатый фитинг быстрого крепежа с внутренней резьбой для труб GIACOTHERM, GIACOFLEX полибутиленовых и медных.

Technical communication 0135EN

PRODUCT CODE	SIZE	■	□
RC573Y004	1/2"x12	10	100
RC573Y007	1/2"x16*	10	100

CERTIFICATION AND SYMBOLS

**RC585M**

Modular manifold, with bayonet connection DN25, with interception valve, push fitting connection.



Module centrale pour collecteur modulaire DN25, avec robinet d'arrêt incorporé et raccord rapide.

Элемент модульного коллектора быстрого монтажа DN25, с отсечным клапаном, с накидной гайкой RC.

PRODUCT CODE	SIZE	■	□
RC585Y054	DN25x16	1	100

Last in production
a equisement de stock

Прекращен производственный выпуск

RC585T

Pair of end manifolds, with bayonet connection DN25, female thread, with interception valve, push fitting connection.



Embout/terminaison DN25 avec robinet d'arrêt incorporé et raccord rapide.

Два крайних элемента модульного коллектора DN25, с внутренней резьбой, с отсечным клапаном, с накидной гайкой RC.

PRODUCT CODE	SIZE	■	□
RC585Y141	3/4"x12xDN25	1	50
RC585Y144	3/4"x16xDN25	1	50
RC585Y151	1"x12xDN25	1	50
RC585Y154	1"x16xDN25	1	50

Last in production
A equisement de stock

Прекращен производственный выпуск

RC150

Push fit equal tee, for GIACOTHERM GIACOFLEX polybutylene and copper pipes.



Té égal avec raccord rapide pour GIACOTHERM, GIACOFLEX PB et cuivre.

T-образный фитинг для труб GIACOTHERM, GIACOFLEX полибутиленовых и медных.

PRODUCT CODE	SIZE	■	□
RC150X004	12	10	-
RC150X007	16*	10	-
RC150X009	20*	10	-
RC150X010	22	5	-

CERTIFICATION AND SYMBOLS



Technical communication 0135EN

R996T



R999



FITTINGS FOR MULTILAYER AND SYNTHETIC PIPE

RACCORDS POUR TUBE PLASTIQUE ET MULTICOUCHES

ФИТИНГИ

R996



R978



R186M

Male plastic tube fitting.

Raccord mâle pour PEX/PB.

Фитинг для пластиковых труб с наружной резьбой.



PRODUCT CODE	SIZE	■	□
R186MY003	3/8"x(12x2)	25	250
R186MY005	3/8"x(12x1,1)	25	250
R186MY007	3/8"x(15x2,5)	25	250
R186MY011	3/8"x(16x2,2)	25	250
R186MY013	3/8"x(16x2)	25	250
R186MY014	3/8"x(16x1,5)*	25	250
R186MY033	1/2"x(12x2)	25	250
R186MY036	1/2"x(12x1,1)*	25	250
R186MY039	1/2"x(14x2,0)	25	250
R186MY041	1/2"x(15x2,5)	25	250
R186MY046	1/2"x(16x2,2)	25	250
R186MY048	1/2"x(16x2)	25	250
R186MY051	1/2"x(16x1,5)*	25	250
R186MY053	1/2"x(17x2)	25	250
R186MY055	1/2"x(18x2,5)	25	250
R186MY057	1/2"x(18x2)	25	250
R186MY060	1/2"x(20x2,8)	25	250
R186MY062	1/2"x(20x2)	25	250
R186MY064	1/2"x(20x1,9)	25	250
R186MY080	3/4"x(16x2,2)	25	250
R186MY082	3/4"x(16x2)	25	250
R186MY086	3/4"x(18x2,5)	25	250
R186MY089	3/4"x(18x2)	25	250
R186MY096	3/4"x(20x2)	25	250
R186MY094	3/4"x(20x2,8)	25	250
R186MY098	3/4"x(20x1,9)	25	250
R186MY103	3/4"x(25x2,5)	10	100
R186MY104	3/4"x(25x2,3)*	10	100
R186MY102	3/4"x(25x3,5)	10	100
R186MY105	3/4x(26x3,0)	10	100
R186MY115	1x(26x3,0)	10	100
R186MY126	1x(32x3,0)	10	100

C.S.T.B. approved n° 14/04-903

APPLICATIONS



Conforme EN681-1

CERTIFICATION AND SYMBOLS



INFO

In accordance with the updating of EN 1254-3 standard.

Conforme à la mise à jour de la norme EN 1254-3.

Соответствует новым поправкам норматива EN 1254-2.

R186F

Female plastic tube fitting.

Raccord femelle pour PEX/PB.

Фитинг для пластиковых труб с внутренней резьбой.



PRODUCT CODE	SIZE	■	□
R186FY003	3/8"x(12x2)	25	250
R186FY004	3/8"x(12x1,1)*	25	250
R186FY033	1/2"x(12x2)	25	250
R186FY035	1/2"x(12x1,1)*	25	250
R186FY041	1/2"x(15x2,5)	25	250
R186FY046	1/2"x(16x2,2)	25	250
R186FY048	1/2"x(16x2)	25	250
R186FY051	1/2"x(16x1,5)*	25	250
R186FY053	1/2"x(17x2)	25	250
R186FY055	1/2"x(18x2,5)	25	250
R186FY057	1/2"x(18x2)	25	250
R186FY062	1/2"x(20x2)	25	250
R186FY064	1/2"x(20x1,9)*	25	250
R186FY081	3/4"x(16x2,2)	25	250
R186FY086	3/4"x(18x2,5)	25	250
R186FY094	3/4"x(20x2,8)	25	250
R186FY096	3/4"x(20x2)	25	250
R186FY098	3/4"x(20x1,9)*	25	250
R186FY103	3/4"x(25x2,5)	10	100
R186FY104	3/4"x(25x2,3)*	10	100
R186FY060	1/2"x(20x2,8)	25	250
R186FY125	1"x(32x2,9)	10	100
R186FY105	3/4x(26x3)	10	100
R186FY115	1x(26x3)	10	100
R186FY126	1x(32x3)	10	100

C.S.T.B. approved n° 14/04-903

APPLICATIONS



Conforme EN681-1

CERTIFICATION AND SYMBOLS



INFO

In accordance with the updating of EN 1254-3 standard.

Conforme à la mise à jour de la norme EN 1254-3.

Соответствует новым поправкам норматива EN 1254-2.

R187M

Male chrome plated fitting for multilayer and synthetic pipes.

Raccord mâle chromé pour tube multicouche et plastique.

Фитинг, с наружной резьбой хромированный для многослойной и полимерной трубы.



PRODUCT CODE	SIZE	■	□
R187MX048	1/2x(16x2,0)	25	250
R187MX057	1/2x(18x2,0)	25	250
R187MX062	1/2x(20x2,0)	25	250
R187MX082	3/4x(16x2)	25	250
R187MX089	3/4x(18x2,0)	25	250
R187MX096	3/4x(20x2)	25	250
R187MX105	3/4x(26x3)	10	100
R187MX115	1x(26x2)	10	100
R187MX126	1x(32x3)	10	100
R187MX130	11/4x(32x3,0)	5	50

APPLICATIONS



Conforme EN681-1

INFO

In accordance with the updating of EN 1254-3 standard.

Conforme à la mise à jour de la norme EN 1254-3.

Соответствует новым поправкам норматива EN 1254-2.

R187D

Chrome plated straight fitting for synthetic or multilayer pipes, male threaded connection with o-ring.

Raccord droit chromé pour les tubes synthétiques ou multicouches, raccord fileté mâle avec O-ring.

Фитинг для многослойных труб, резьбовое внешнее соединение с o-ring.



PRODUCT CODE	SIZE	■	□
R187DX048	1/2x(16x2,0)	25	250

APPLICATIONS



Conforme EN681-1

INFO

In accordance with the updating of EN 1254-3 standard.

Conforme à la mise à jour de la norme EN 1254-3.

Соответствует новым поправкам норматива EN 1254-2.

R187F

Female chrome plated fitting for multilayer and synthetic pipes.

Raccord femelle chromé pour tube multicouche et plastique.

Фитинг, с внутренней резьбой хромированный для многослойной и полимерной трубы.

PRODUCT CODE	SIZE	■	□
R187FX048	1/2x(16x2,0)	25	250
R187FX052	1/2x(18x2)	25	250
R187FX062	1/2x(20x2,0)	25	250
R187FX082	3/4x(16x2)	25	250
R187FX092	3/4x(18x2)	25	250
R187FX096	3/4x(20x2)	25	250
R187FX105	3/4x(26x3)	10	100
R187FX115	1x(26x3)	10	100
R187FX126	1x(32x3)	10	100

APPLICATIONS



Conforme EN681-1

INFO

In accordance with the updating of EN 1254-3 standard.

Conforme à la mise à jour de la norme EN 1254-3.

Соответствует новым поправкам норматива EN 1254-3.

R562AM

90° elbow, male thread, for GIACOTHERM, GIACOFLEX and multilayer pipes.

Raccord à sertir pour GIACOTHERM GIACOFLEX PB et multicouche.

Коленчатый фитинг 90° с наружной резьбой для труб GIACOTHERM, GIACOFLEX и многослойных.

chrome plated - chromé - хромированный

PRODUCT CODE	SIZE	■	□
R562MX048	1/2" x(16x2)	25	250
R562MX052	1/2" M x(18x2)	10	100
R562MX057	1/2" x(20x2)	10	100
R562MX060	3/4" x(16x2)	10	100
R562MX061	3/4" x(20x2)	10	100
R562MX062	3/4" x(26x3)	10	100
R562MX120	1" x(26x3)	5	50
R562MX126	1" x(32x3)	5	50

brass finish - laiton - нехромированный

PRODUCT CODE	SIZE	■	□
R562MY048	1/2" x(16x2)	25	250
R562MY057	1/2" x(20x2)	10	100
R562MY062	3/4" x(26x3)	10	100
R562MY126	1" x(32x3)	5	50

APPLICATIONS



Conforme EN681-1

R560AM

Straight fitting, for GIACOTHERM GIACOFLEX and multilayer pipes.

Raccord à sertir pour GIACOTHERM GIACOFLEX PB et multicouche.

Прямой фитинг для труб GIACOTHERM, GIACOFLEX, многослойных.

brass finish - chromé - хромированный

PRODUCT CODE	SIZE	■	□
R560MX048	(16x2)	10	100
R560MX052	(18x2)	10	100
R560MX057	(20x2)	10	100
R560MX062	(26x3)	5	50
R560MX126	(32x3)	5	50

chrome plated - laiton - нехромированный

PRODUCT CODE	SIZE	■	□
R560MY048	(16x2)	10	100
R560MY057	(20x2)	10	100
R560MY062	(26x3)	5	50
R560MY126	(32x3)	5	50

APPLICATIONS



Conforme EN681-1

R563AM

90° elbow, female thread, for GIACOTHERM, GIACOFLEX and multilayer pipes.

Raccord à sertir pour GIACOTHERM GIACOFLEX PB et multicouche.

Коленчатый фитинг 90° с внутренней резьбой для труб GIACOTHERM, GIACOFLEX и многослойных.

chrome plated - chromé - хромированный

PRODUCT CODE	SIZE	■	□
R563MX048	1/2" x(16x2)	25	250
R563MX052	1/2" x(18x2)	25	250
R563MX057	1/2" x(20x2)	10	100
R563MX060	3/4" x(16x2)	10	100
R563MX061	3/4" x(20x2)	10	100
R563MX062	3/4" x(26x3)	10	100
R563MX120	1" x(26x3)	5	50
R563MX126	1" x(32x3)	5	50

brass finish - laiton - нехромированный

PRODUCT CODE	SIZE	■	□
R563MY048	1/2" x(16x2)	25	250
R563MY057	1/2" x(20x2)	10	100
R563MY062	3/4" x(26x3)	10	100
R563MY126	1" x(32x3)	5	50

APPLICATIONS



Conforme EN681-1

R561AM

90° elbow for GIACOTHERM GIACOFLEX and multilayer pipes.

Raccord à sertir pour GIACOTHERM GIACOFLEX PB et multicouche.

Коленчатый фитинг 90° для труб GIACOTHERM, GIACOFLEX и многослойных.

chrome plated - chromé - хромированный

PRODUCT CODE	SIZE	■	□
R561MX048	(16x2)	10	100
R561MX052	(18x2)	10	100
R561MX057	(20x2)	10	100
R561MX062	(26x3)	5	50
R561MX126	(32x3)	5	25

brass finish - laiton - нехромированный

PRODUCT CODE	SIZE	■	□
R561MY048	(16x2)	10	100
R561MY057	(20x2)	10	100
R561MY062	(26x3)	5	50
R561MY126	(32x3)	5	25

APPLICATIONS



Conforme EN681-1

R564AM

Tee fitting for GIACOTHERM GIACOFLEX and multilayer pipes.

Raccord à sertir pour GIACOTHERM GIACOFLEX PB et multicouche.

T-образный фитинг для труб GIACOTHERM, GIACOFLEX и многослойных.

chrome plated - chromé - хромированный

PRODUCT CODE	SIZE	■	□
R564MX048	(16x2)	10	100
R564MX052	(18x2)	5	50
R564MX057	(20x2)	10	100
R564MX062	(26x3)	5	50
R564MX126	(32x3)	5	25

brass finish - laiton - нехромированный

PRODUCT CODE	SIZE	■	□
R564MY048	(16x2)	10	100
R564MY057	(20x2)	10	100
R564MY062	(26x3)	5	50
R564MY126	(32x3)	5	25

APPLICATIONS



Conforme EN681-1

R566AM**Fitting**

Raccord à sertir pour GIACOTHERM, GIACOFLEX PB et multicouche.

Фитинг.



PRODUCT CODE	SIZE	■	□
R566MX053	(20x2)x(16x2)	10	100
R566MX060	(26x3)x(20x2)	5	50
R566MX076	(32x3)x(26x3)	5	50

R568AM**Tee fitting, for GIACOTHERM, GIACOFLEX and multilayer pipes male thread.**

Raccord à sertir pour GIACOTHERM GIACOFLEX PB et multicouche.

T-образный фитинг с наружной резьбой для труб GIACOTHERM, GIACOFLEX и многослойных.



chrome plated - chromé - хромированный

PRODUCT CODE	SIZE	■	□
R568MX048	(16x2)x1/2"x(16x2)	10	100
R568MX057	(20x2)x1/2"x(20x2)	10	100
R568MX061	(20x2)x3/4"x(20x2)	5	50
R568MX062	(26x3)x3/4"x(26x3)	5	50
R568MX126	(32x3)x1"x(32x3)	5	25

brass finish - laiton - нехромированный

PRODUCT CODE	SIZE	■	□
R568MY048	(16x2)x1/2"x(16x2)	10	100
R568MY057	(20x2)x1/2"x(20x2)	10	100
R568MY062	(26x3)x3/4"x(26x3)	5	50
R568MY126	(32x3)x1"x(32x3)	5	25

APPLICATIONS

Conforme EN681-1

R569AM**Tee fitting, for GIACOTHERM, GIACOFLEX and multilayer pipes.**

Raccord à sertir pour GIACOTHERM, GIACOFLEX PB et multicouche.

T-образный фитинг для труб GIACOTHERM, GIACOFLEX и многослойных.



chrome plated - chromé - хромированный

PRODUCT CODE	SIZE	■	□
R569MX048	(16x2)x1/2"x(16x2)	10	100
R569MX052	(18x2)x1/2"x(18x2)	10	100
R569MX057	(20x2)x1/2"x(20x2)	10	100
R569MX061	(20x2)x3/4"x(20x2)	5	50
R569MX062	(26x3)x3/4"x(26x3)	5	50
R569MX120	(26x3)x1"x(26x3)	5	50
R569MX126	(32x3)x1"x(32x3)	5	25

brass finish - laiton - нехромированный

PRODUCT CODE	SIZE	■	□
R569MY048	(16x2)x1/2"x(16x2)	10	100
R569MY057	(20x2)x1/2"x(20x2)	10	100
R569MY062	(26x3)x3/4"x(26x3)	5	50
R569MY126	(32x3)x1"x(32x3)	5	25

APPLICATIONS

Conforme EN681-1

R572AM**90° elbow with wall bracket, female iron thread and fitting connection for GIACOTHERM, GIACOFLEX multilayer.**

Raccord à sertir pour GIACOTHERM GIACOFLEX PB et multicouche.

Коленчатый фитинг 90° с кронштейном и внутренней резьбой для труб GIACOTHERM, GIACOFLEX и многослойных.



chrome plated - chromé - хромированный

PRODUCT CODE	SIZE	■	□
R572MX048	1/2"x(16x2)	10	100
R572MX057	1/2"x(20x2)	10	100

brass finish - laiton - нехромированный

PRODUCT CODE	SIZE	■	□
R572MY048	1/2"x(16x2)	10	100
R572MY057	1/2"x(20x2)	10	100

APPLICATIONS

Conforme EN681-1



R996T

R999

R996

R978

ADAPTORS FOR MULTILAYER AND SYNTHETIC PIPE

ADAPTATEUR POUR TUBE PLASTIQUE ET MULTICOUCHES
ПЕРЕХОДНИКИ ДЛЯ ПЛАСТИКОВЫХ И МНОГОСЛОЙНЫХ ТРУБ

R179

Synthetic pipe adaptor.

Adaptateur pour tube plastique.

Переходник для полимерных труб.



PRODUCT CODE	SIZE	■	□
R179X072	18x(16x2,7)	25	250
R179X076	18x(16x1,8)	25	250
R179X077	18x(16x1,5)**	25	250
R179X079	18x(17x2,5)	25	250
R179X082	18x(18x2,5)	25	250
R179X086	18x(20x3,4)	25	250
R179X087	18x(20x2,8)	25	250
R179X091	18x(20x1,9)**	25	250
R179X092	18x(21x2,5)	25	250
R179X094	18x(15x2)	25	250
R179X095	18x(22x2)	25	250
R179X102	22x(20x1,9)*	25	250
R179X103	22x(25x3,5)	25	250
R179X104	22x(25x2,5)	25	250
R179X105	22x(25x2,3)*	25	250
R179X025	16x(12x2)	25	250
R179X026	16x(12x1,8)	25	250
R179X027	16x(12x1,1)*	25	250
R179X033	16x(15x2,5)	25	250
R179X034	16x(15x2)	25	250
R179X040	16x(16x1,8)	25	250
R179X041	16x(16x1,5)*	25	250
R179X044	16x(17,6x3)	25	250
R179X046	16x(18x2,5)	25	250
R179X051	16x(20x1,9)*	25	250
R179X058	18x(14x1,5)	25	250
R179X060	18x(14x1)	25	250
R179X062	18x(12x2)	25	250
R179X063	18x(12x1,1)*	25	250
R179X068	18x(14,5x1,7)	25	250
R179X070	18x(15x2,5)	25	250
R179AY005	22x(25x3,5)	25	250
R179AY071	28x(32x2,9)	10	100
R179AY070	28x(32x4,4)	10	100

APPLICATIONS



Conforme EN681-1

CERTIFICATION AND SYMBOLS

**R179AM**

Plastic pipe adaptor connection.

Adaptateur pour tube plastique raccordement.

Переходник для пластиковой трубы с соединением.



PEX/Al/PEX - multicouche -

PRODUCT CODE	SIZE	■	□
R179MX012	16x(14x2)	25	250
R179MX013	16x(16x2,2)	25	250
R179MX014	16x(16x2)	25	250
R179MX015	16x(18x2)	25	250
R179MX016	16x(16,2x2,6)	25	250
R179MX019	16x(17x2,0)	25	250
R179MX020	16x(20x2)	25	250
R179MX021	16x(20x2,5)	25	250
R179MX036	16x(20x2,25)	1	250
R179MX037	16x(20x2,9)*	1	250
R179MX038	16x(20x2,8)	1	250
R179MX022	18x(14x2)	25	250
R179MX023	18x(16x2,2)	25	250
R179MX024	18x(16x2)	25	250
R179MX025	18x(18x2)	25	250
R179MX026	18x(20x2)	25	250
R179MX027	18x(20x2,5)	25	250
R179MX028	18x(16,2x2,6)	25	250
R179MX029	18x(20x2,9)	25	250
R179MX030	18x(17,5x2,3)	25	250
R179MX034	18x(17x2,0)	25	250
R179MX035	18x(20x2,25)	25	250
R179MX041	22x(20x2,0)	1	250
R179MX045	28x(32x3)	10	100

eurocone - eurocône - евроконус

PRODUCT CODE	SIZE	■	□
R179EX023	3/4"x(14x2)	25	250
R179EX043	3/4"x(15x1,7)	25	250
R179EX024	3/4"x(16x2)	25	250
R179EX025	3/4"x(17x2,0)	25	250
R179EX026	3/4"x(18x2)	25	250
R179EX027	3/4"x(20x2)	25	250

APPLICATIONS

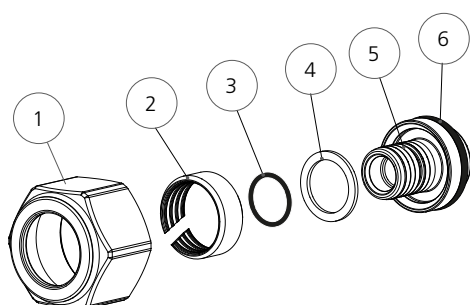

Conforme EN681-1

R179AM

- 1) Nut
- 2) Element of mechanical seal
- 3) Internal "o-ring"
- 4) Separation ring
- 5) Adapter and pipe holder
- 6) External "o-ring"

RS179M

Push fit adaptor for multilayer pipe.

Adaptateur rapide pour tube multicouches.

Пуш-фиттинг для металлополимерной трубы.



PRODUCT CODE	SIZE	■	□
RS179X022	16x(16x2,0)	1	250

APPLICATIONS



Conforme EN681-1

FITTINGS FOR ADAPTERS

RACCORDS POUR ADAPTATEURS

ПЕРЕХОДНИКИ

R180R



Straight fitting adaptor-male connections, to complete with R178 or R179.

Raccord mâle ajouter R178 ou R179.

Прямой фитинг-переходник, с наружной резьбой, соединяется с R178 или R179.

brass finish - laiton - нехромированный

PRODUCT CODE	SIZE	■	□
R180RY008	3/8"x18	50	500
R180RY015	1/2"x16	50	500
R180RY016	1/2"x18	50	500
R180RY020	3/4"x16	25	250
R180RY021	3/4"x18	25	250
R180RY023	3/4"x22	25	250
R180RY027	1"x22	25	250
R180RY028	1"x28	10	100
R180RY034	1"1/4x28	10	100

chrome plated - chromé - хромированный

PRODUCT CODE	SIZE	■	□
R180RX015	1/2"x16	50	500
R180RX016	1/2"x18	50	500

R180FR



Straight fitting adaptor-female connections, to complete with R178 or R179.

Raccord de base femelle ajouter R178 et R179.

Прямой фитинг-переходник, с внутренней резьбой, соединяется с R178 или R179.

brass finish - laiton - нехромированный

PRODUCT CODE	SIZE	■	□
R180RY048	3/8" x18-R553	50	500
R180RY049	3/8" x3/4" EURC	50	500
R180RY055	1/2"x16	50	500
R180RY056	1/2"x18	50	500
R180RY057	1/2" x3/4" E	50	500
R180RY060	3/4"x16	25	250
R180RY061	3/4"x18	25	250
R180RY063	3/4"x22	25	250
R180RY068	1"x28	10	100

chrome plated - chromé - хромированный

PRODUCT CODE	SIZE	■	□
R180RX055	1/2"x16	50	500
R180RX056	1/2"x18	50	500

R560R



Straight fitting adaptor connections to complete with R178 or R179.

Nipple ajouter R178 ou R179.

Прямой фитинг-переходник для R178 или R179.

brass finish - laiton - нехромированный

PRODUCT CODE	SIZE	■	□
R560RY007	ø16	25	250
R560RY008	ø18	25	250
R560RY009	ø22	25	250
R560RY010	ø28	10	100

chrome plated - chromé - хромированный

PRODUCT CODE	SIZE	■	□
R560RX007	ø16	25	250
R560RX008	ø18	25	250

R561R



Bent fitting adaptor connections, to complete with R178 or R179.

Coude ajouter R178 ou R179.

Угловой фитинг-переходник для R178 или R179.

brass finish - laiton - нехромированный

PRODUCT CODE	SIZE	■	□
R561RY007	ø16	25	250
R561RY008	ø18	25	250
R561RY009	ø22	10	100
R561RY010	ø28	10	100

chrome plated - chromé - хромированный

PRODUCT CODE	SIZE	■	□
R561RX007	ø16	25	250
R561RX008	ø18	25	250

R562R



Bent fitting adaptor connections, to complete with R178 or R179.

Coude pas du gaz et alésage, ajouter R178 ou R179.

Угловой фитинг-переходник для R178 или R179.

brass finish - laiton - нехромированный

PRODUCT CODE	SIZE	■	□
R562RY015	1/2"x16	25	250
R562RY016	1/2"x18	25	250
R562RY021	3/4"x18	25	250
R562RY023	3/4"x22	10	100
R562RY027	1"x22	10	100
R562RY028	1"x28	10	100
R562RY034	1"1/4x28	10	100

chrome plated - chromé - хромированный

PRODUCT CODE	SIZE	■	□
R562RX015	1/2"x16	25	250
R562RX016	1/2"x18	25	250

R563R



Bent fitting adaptor-female connections, to complete with R178 or R179.

Coude pas du gaz et alésage, ajouter R178 ou R179.

Угловой фитинг-переходник с внутренней резьбой для R178 или R179.

brass finish - laiton - нехромированный

PRODUCT CODE	SIZE	■	□
R563RY015	1/2"x16	25	250
R563RY016	1/2"x18	25	250
R563RY021	3/4"x18	25	250
R563RY023	3/4"x22	10	100
R563RY028	1"x28	10	100

chrome plated - chromé - хромированный

PRODUCT CODE	SIZE	■	□
R563RX015	1/2"x16	25	250
R563RX016	1/2"x18	25	250

R568R



Tee adaptor - adaptor - male connections, to complete with R178 or R179.

Té pas du gaz et alésage, ajouter R178 ou R179.

T-образный фитинг-переходник с наружной резьбой для R178 или R179.

PRODUCT CODE	SIZE	■	□
R568RY015	16x1/2"x16	25	250
R568RY016	18x1/2"x18	25	250
R568RY021	18x3/4"x18	10	100
R568RY023	22x3/4"x22	10	100
R568RY028	28x1"x28	5	50

INFO



R570R

Tee male - adaptor - adaptor connections, to complete with R178 or R179.

Té avec 2 adaptateurs et pas du gaz, ajouter R178 ou R179.

T-образный фитинг-переходник с наружной резьбой для R178 или R179.



PRODUCT CODE	SIZE	■	□
R570RY015	1/2"x16	25	250
R570RY016	1/2"x18	25	250
R570RY021	3/4"x18	10	100
R570RY023	3/4"x22	10	100

R571R

Tee female-adaptor-adaptor connections, to complete with R178 or R179.

Té avec pas du gaz et 2 alésage ajouter R178 ou R179.

T-образный фитинг-переходник с внутренней резьбой для R178 или R179.



PRODUCT CODE	SIZE	■	□
R571RY015	1/2"x16	25	250
R571RY016	1/2"x18	25	250
R571RY021	3/4"x18	10	100
R571RY023	3/4"x22	10	100

R572R

Angle fitting with wall bearing female-adaptor connections, to complete with R178 or R179.

Coude avec 2 adaptateurs et pas du gaz, ajouter R178 ou R179.

Угловой фитинг-переходник с настенным креплением с внутренней резьбой для R178 или R179.



brass finish - laiton - нехромированный

PRODUCT CODE	SIZE	■	□
R572RY002	1/2"x16	10	100
R572RY003	1/2"x18	10	100

chrome plated - chromé - хромированный

PRODUCT CODE	SIZE	■	□
R572RX002	1/2"x16	10	100
R572RX003	1/2"x18	10	100

R177

Adaptor to convert copper to iron connection, chrome plated.

Adaptateur pour passer de cuivre à acier, finition chromée.

Переходник для соединения медной и стальной трубы, хромированный.



PRODUCT CODE	SIZE	■	□
R177X010	16x1/2"	25	250

R564R

Tee adaptor connections, to complete with R178 or R179.

Té pas du gaz et alésage, ajouter R178 ou R179.

T-образный фитинг-переходник для R178 или R179.



brass finish - laiton - нехромированный

PRODUCT CODE	SIZE	■	□
R564RY007	ø16	25	250
R564RY008	ø18	25	250
R564RY009	ø22	10	100
R564RY010	ø28	5	50

chrome plated - chromé - хромированный

PRODUCT CODE	SIZE	■	□
R564RX007	ø16	25	250
R564RX008	ø18	25	250

R567

Adaptor 26/19 to iron.

Raccord pour passer la robinetterie ou les collecteurs alésage au pas gaz 1/2" femelle.

Переходник с выводом для железной трубы.



PRODUCT CODE	SIZE	■	□
R567Y016	18x1/2"	50	500

R569R

Tee adaptor - adaptor - female connections, to complete with R178 or R179.

Té avec 2 adaptateurs et pas du gaz, ajouter R178 ou R179.

T-образный фитинг-переходник с внутренней резьбой для R178 или R179.



PRODUCT CODE	SIZE	■	□
R569RY015	16x1/2"x16	25	250
R569RY016	18x1/2"x18	25	250
R569RY021	18x3/4"x18	10	100
R569RY023	22x3/4"x22	10	100

**R178R**

Adaptor for copper or plastic pipe.

Adaptateur laiton ou chromé tube cuivre ou PEX/PB.

Переходник для медной или пластиковой трубы.

brass finish - laiton - нехромированный

PRODUCT CODE	SIZE	■	□
R178RY011	16x18	50	500
R178RY012	18x22	25	250
R178RY013	18x3/4"E	25	250

chrome plated - chromé - хромированный

PRODUCT CODE	SIZE	■	□
R178RX003	16x1/2"	50	500
R178RX011	16x18	50	500
R178RX012	18x22	25	250
R178RX013	18x3/4"	25	250



COPPER

ADAPTORS FOR COPPER TUBE

ADAPTATEUR POUR TUBE CUIVRE

ПЕРЕХОДНИКИ ДЛЯ МЕДНЫХ ТРУБ

R178

Copper tube adaptor.

Adaptateur nickelé e chromé pour tube cuivre.

Переходник для медной трубы.

In accordance with EN 681-1 - -

PRODUCT CODE	SIZE	■	□
R178X012	16x10	50	500
R178X013	16x12	50	500
R178X015	16x14	50	500
R178X016	16x15	50	500
R178X018	16x16	50	500
R178X031	18x10	50	500
R178X032	18x12	50	500
R178X033	18x14	50	500
R178X034	18x15	50	500
R178X035	18x16	50	500
R178X036	18x18	50	500
R178X041	22x16	50	500
R178X042	22x18	25	250
R178X043	22x22	50	500

In accordance with EN 682-EN549 - -

PRODUCT CODE	SIZE	■	□
R178X112	16x10	50	500
R178X113	16x12	50	500
R178X115	16x14	50	500
R178X116	16x15	50	500
R178X118	16x16	50	500
R178X134	18x15	50	500
R178X135	18x16	50	500
R178X136	18x18	50	500

APPLICATIONS



Conforme EN681-1

INFO

Gas installations and fluid hydrocarbons: yellow o-ring in accordance with EN 549 - EN 682 standard. Water distribution systems (drinking water and heating): black o-ring in accordance with EN 681-1 standard.

Installation gaz et hydrocarbure liquide.
Joint O-ring jaune conforme EN 549 - EN 682.
Installation de distribution d'eau (eau chaude et froide sanitaire et chauffage): joint O-Ring noir conforme à la norme EN 681-1.

Системы для газа и жидких углеводородов: желтая кольцевая прокладка в соответствии с нормативом EN 549 - EN 682. Водораспределительные системы (водопровод и отопление): черная кольцевая прокладка в соответствии с нормативом EN 681-1.

R178E

Copper tube adaptor eurocone connections.

Adaptateur pour tube cuivre pour raccord Eurocône.

Переходник для медной трубы с соединением евроконус.

PRODUCT CODE	SIZE	■	□
R178EX104	3/4" Ex15	50	500
R178EX112	3/4" Ex12	50	500
R178EX113	3/4" Ex14	50	500
R178EX115	3/4" Ex16	50	500
R178EX116	3/4" Ex18	50	500

R178C

Copper tube adaptor

Raccords à compression compatible pour tube cuivre.

Компактный переходник для медной трубы.

PRODUCT CODE	SIZE	■	□
R178CX012	16x10	50	500
R178CX013	16x12	50	500
R178CX015	16x14	50	500
R178CX018	16x16	50	500

R178

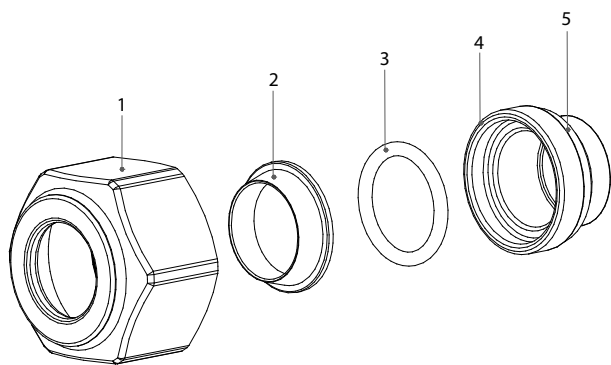

- 1) Nut
- 2) Element of mechanical seal
- 3) Internal "o-ring"
- 4) Adapter
- 5) External "o-ring"

R178C

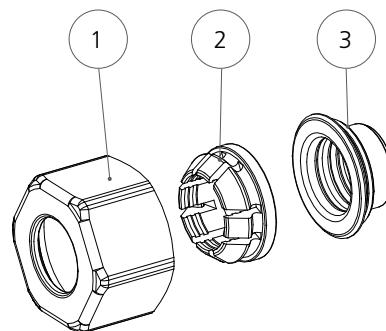

- 1) Nut
- 2) Element of mechanical seal
- 3) Element of hydraulic seal

COPPER

FITTINGS FOR COPPER TUBE
RACCORDS POUR TUBE CUIVRE
ФИТИНГИ ДЛЯ МЕДНЫХ ТРУБ
R180M

Male fitting with mono-cone and double OR for copper pipe.



Raccord mâle avec monocône double Oring pour tube cuivre.

Фитинг с наружной резьбой, конусное соединение, двойная кольцевая прокладка, для медных труб.

PRODUCT CODE	SIZE	■	□
R180MY01	3/8"x6	25	250
R180MY02	3/8"x8	25	250
R180MY03	3/8"x10	25	250
R180MY04	3/8"x12	25	250
R180MY05	3/8"x14	25	250
R180MY06	3/8"x15	25	250
R180MY07	3/8"x16	25	250
R180MY10	1/2"x8	25	250
R180MY11	1/2"x10	25	250
R180MY12	1/2"x12	25	250
R180MY13	1/2"x14	25	250
R180MY14	1/2"x15	25	250
R180MY15	1/2"x16	25	250
R180MY16	1/2"x18	25	250
R180MY120	3/4"x16	25	250
R180MY121	3/4"x18	25	250
R180MY122	3/4"x20	10	100
R180MY123	3/4"x22	10	100
R180MY128	1"x28	10	100

APPLICATIONS

INFO

Gas installations and fluid hydrocarbons: yellow o-ring in accordance with EN 549 -EN 682 standard. Water distribution systems (drinking water and heating): black o-ring in accordance with EN 681-1 standard. In accordance with the updating of EN 1254-2 standard.

Conforme à la mise à jour de la norme EN 1254-2 Installation gaz et hydrocarbure liquide. Joint O-ring jaune conforme EN 549 - EN 682. Installation de distribution d'eau (eau chaude et froide sanitaire et chauffage): joint O-Ring noir conforme à la norme EN 681-1.

Системы для газа и жидких углеводородов: желтая кольцевая прокладка в соответствии с нормативом EN 549 - EN 682. Водораспределительные системы (водопровод и отопление): черная кольцевая прокладка в соответствии с нормативом EN 681-1. Соответствует новым поправкам норматива EN 1254-2.

R180F

Female fitting with mono-cone and double OR for copper pipe.



Raccord femelle avec monocône double Oring pour tube cuivre.

Фитинг с внутренней резьбой, конусное соединение, двойная кольцевая прокладка, для медных труб.

PRODUCT CODE	SIZE	■	□
R180FY02	3/8"x8	25	250
R180FY03	3/8"x10	25	250
R180FY04	3/8"x12	25	250
R180FY05	3/8"x14	25	250
R180FY11	1/2"x10	25	250
R180FY12	1/2"x12	25	250
R180FY13	1/2"x14	25	250
R180FY14	1/2"x15	25	250
R180FY15	1/2"x16	25	250
R180FY16	1/2"x18	25	250
R180FY120	3/4"x16	25	250
R180FY121	3/4"x18	25	250
R180FY123	3/4"x22	10	100
R180FY128	1"x28	10	100
R180FY135	1"x4x35	5	50

APPLICATIONS

INFO

Gas installations and fluid hydrocarbons: yellow o-ring in accordance with EN 549 -EN 682 standard. Water distribution systems (drinking water and heating): black o-ring in accordance with EN 681-1 standard. In accordance with the updating of EN 1254-2 standard.

Conforme à la mise à jour de la norme EN 1254-2 Installation gaz et hydrocarbure liquide. Joint O-ring jaune conforme EN 549 - EN 682. Installation de distribution d'eau (eau chaude et froide sanitaire et chauffage): joint O-Ring noir conforme à la norme EN 681-1.

Системы для газа и жидких углеводородов: желтая кольцевая прокладка в соответствии с нормативом EN 549 - EN 682. Водораспределительные системы (водопровод и отопление): черная кольцевая прокладка в соответствии с нормативом EN 681-1. Соответствует новым поправкам норматива EN 1254-2.

R560

Straight coupling copper-copper connections.

Nipple et raccord cuivre.

Прямое соединение для медных труб.



PRODUCT CODE	SIZE	■	□
R560Y002	ø8	25	500
R560Y003	ø10	25	500
R560Y004	ø12	25	250
R560Y005	ø14	25	250
R560Y006	ø15	25	250
R560Y007	ø16	25	250
R560Y008	ø18	25	250
R560Y009	ø22	10	100
R560Y010	ø28	10	100
R560Y011	ø35	5	50

APPLICATIONS

Conforme EN681-1

INFO

In accordance with the updating of EN 1254-2 standard.

Conforme à la mise à jour de la norme EN 1254-2.

Соответствует новым поправкам норматива EN 1254-2.

R561

Elbow copper-copper connections.

Coude cuivre.

Угловое соединение для медных труб.



PRODUCT CODE	SIZE	■	□
R561Y002	ø8	25	500
R561Y003	ø10	25	500
R561Y004	ø12	25	250
R561Y005	ø14	25	250
R561Y006	ø15	25	250
R561Y007	ø16	25	250
R561Y008	ø18	10	100
R561Y009	ø22	10	100
R561Y010	ø28	10	100
R561Y011	ø35	5	50

APPLICATIONS

Conforme EN681-1

INFO

In accordance with the updating of EN 1254-2 standard.

Conforme à la mise à jour de la norme EN 1254-2.

Соответствует новым поправкам норматива EN 1254-2.

R562**Elbow copper-male connections.**

Coude mâle pas du gaz alésage pour tube cuivre.

Угловое соединение с наружной резьбой, для медных труб.



PRODUCT CODE	SIZE	■	□
R562Y102	3/8"x8	25	250
R562Y103	3/8"x10	25	250
R562Y104	3/8"x12	25	250
R562Y105	3/8"x14	25	250
R562Y111	1/2"x10	25	250
R562Y112	1/2"x12	25	250
R562Y113	1/2"x14	25	250
R562Y114	1/2"x15	25	250
R562Y115	1/2"x16	25	250
R562Y116	1/2"x18	10	100
R562Y121	3/4"x18	10	100
R562Y123	3/4"x22	10	100
R562Y128	1"x28	10	100
R562Y135	1"1/4x35	5	50

APPLICATIONS**INFO**

Gas installations and fluid hydrocarbons: yellow o-ring in accordance with EN 549-EN 682 standard. Water distribution systems (drinking water and heating): black o-ring in accordance with EN 681-1 standard. In accordance with the updating of EN 1254-2 standard.

Conforme à la mise à jour de la norme EN 1254-2 Installation gaz et hydrocarbure liquide. Joint O-ring jaune conforme EN 549 - EN 682. Installation de distribution d'eau (eau chaude et froide sanitaire et chauffage): joint O-Ring noir conforme à la norme EN 681-1.

Соответствует новым поправкам норматива EN 1254-2 Системы для газа и жидких углеводородов: желтая кольцевая прокладка в соответствии с нормативом EN 549 - EN 682. Водораспределительные системы (водопровод и отопление): черная кольцевая прокладка в соответствии с нормативом EN 681-1.

R563**Elbow copper-female connections.**

Coude femelle pas du gaz alésage pour tube cuivre.

Угловое соединение с внутренней резьбой, для медных труб.



PRODUCT CODE	SIZE	■	□
R563Y102	3/8"x8	25	250
R563Y103	3/8"x10	25	250
R563Y104	3/8"x12	25	250
R563Y105	3/8"x14	25	250
R563Y111	1/2"x10	25	250
R563Y112	1/2"x12	25	250
R563Y113	1/2"x14	25	250
R563Y114	1/2"x15	25	250
R563Y115	1/2"x16	25	250
R563Y116	1/2"x18	10	100
R563Y121	3/4"x18	10	100
R563Y123	3/4"x22	10	100
R563Y128	1"x28	5	50
R563Y135	1"1/4x35	5	50

APPLICATIONS**INFO**

Gas installations and fluid hydrocarbons: yellow o-ring in accordance with EN 549-EN 682 standard. Water distribution systems (drinking water and heating): black o-ring in accordance with EN 681-1 standard. In accordance with the updating of EN 1254-2 standard.

Conforme à la mise à jour de la norme EN 1254-2 Installation gaz et hydrocarbure liquide. Joint O-ring jaune conforme EN 549 - EN 682. Installation de distribution d'eau (eau chaude et froide sanitaire et chauffage): joint O-Ring noir conforme à la norme EN 681-1.

Соответствует новым поправкам норматива EN 1254-2 Системы для газа и жидких углеводородов: желтая кольцевая прокладка в соответствии с нормативом EN 549 - EN 682. Водораспределительные системы (водопровод и отопление): черная кольцевая прокладка в соответствии с нормативом EN 681-1.

R570**Tee male - copper - copper connections.**

Raccord cuivre filetage pas du gaz.

Т-образное соединение с наружной резьбой, для медных труб.



PRODUCT CODE	SIZE	■	□
R570Y014	15x1/2"x15	10	100

APPLICATIONS

Conforme EN681-1

INFO

In accordance with the updating of EN 1254-2 standard.

Conforme à la mise à jour de la norme EN 1254-2.

Соответствует новым поправкам норматива EN 1254-2.

R564**Tee copper tube connections.**

Té cuivre.

Т-образное соединение для медных труб.



PRODUCT CODE	SIZE	■	□
R564Y002	ø8	25	250
R564Y003	ø10	25	250
R564Y004	ø12	10	100
R564Y005	ø14	10	100
R564Y006	ø15	10	100
R564Y007	ø16	10	100
R564Y008	ø18	10	100
R564Y009	ø22	10	100
R564Y010	ø28	5	50
R564Y011	ø35	5	25

APPLICATIONS

Conforme EN681-1

INFO

In accordance with the updating of EN 1254-2 standard.

Conforme à la mise à jour de la norme EN 1254-2.

Соответствует новым поправкам норматива EN 1254-2.

R571**Tee female-copper-copper connections.**

Raccord cuivre filetage pas du gaz.

Т-образное соединение с внутренней резьбой, для медных труб.



PRODUCT CODE	SIZE	■	□
R571Y016	18x1/2"x18	10	100
R571Y021	18x3/4"x18	10	100

APPLICATIONS

Conforme EN681-1

R568

Tee copper-copper-male connections.

Té mâle pas du gaz double alésage pour tube cuivre.

T-образное соединение с наружной резьбой, для медных труб.



PRODUCT CODE	SIZE	■	□
R568Y102	8x3/8"x8	25	250
R568Y103	10x3/8"x10	25	250
R568Y104	12x3/8"x12	25	250
R568Y105	14x3/8"x14	25	250
R568Y112	12x1/2"x12	10	100
R568Y113	14x1/2"x14	10	100
R568Y114	15x1/2"x15	10	100
R568Y115	16x1/2"x16	10	100
R568Y116	18x1/2"x18	10	100
R568Y121	18x3/4"x18	10	100
R568Y123	22x3/4"x22	10	100
R568Y128	28x1"x28	5	50
R568Y135	35x1"1/4x35	5	50

APPLICATIONS



INFO

Gas installations and fluid hydrocarbons: yellow o-ring in accordance with EN 549 - EN 682 standard. Water distribution systems (drinking water and heating): black o-ring in accordance with EN 681-1 standard. In accordance with the updating of EN 1254-2 standard.

Conforme à la mise à jour de la norme EN 1254-2 Installation gaz et hydrocarbure liquide.

Joint O-ring jaune conforme EN 549 - EN 682.

Installation de distribution d'eau (eau chaude et froide sanitaire et chauffage): joint O-Ring noir conforme à la norme EN 681-1.

Соответствует новым поправкам норматива EN 1254-2 Системы для газа и жидких углеводородов: желтая кольцевая прокладка в соответствии с нормативом EN 549 - EN 82. Водораспределительные системы (водопровод и отопление): черная кольцевая прокладка в соответствии с нормативом EN 681-1.

R569

Tee copper - copper - female connections.

Té femelle pas du gaz double alésage pour tube cuivre.

T-образное соединение с внутренней резьбой, для медных труб.



PRODUCT CODE	SIZE	■	□
R569Y102	8x3/8"x8	25	250
R569Y103	10x3/8"x10	25	250
R569Y104	12x3/8"x12	25	250
R569Y105	14x3/8"x14	25	250
R569Y112	12x1/2"x12	10	100
R569Y113	14x1/2"x14	10	100
R569Y114	15x1/2"x15	10	100
R569Y115	16x1/2"x16	10	100
R569Y116	18x1/2"x18	10	100
R569Y121	18x3/4"x18	10	100
R569Y123	22x3/4"x22	10	100
R569Y128	28x1"x28	5	50
R569Y135	35x1"1/4x35	5	50

APPLICATIONS



INFO

Gas installations and fluid hydrocarbons: yellow o-ring in accordance with EN 549 - EN 682 standard. Water distribution systems (drinking water and heating): black o-ring in accordance with EN 681-1 standard. In accordance with the updating of EN 1254-2 standard.

Conforme à la mise à jour de la norme EN 1254-2 Installation gaz et hydrocarbure liquide.

Joint O-ring jaune conforme EN 549 - EN 682.

Installation de distribution d'eau (eau chaude et froide sanitaire et chauffage): joint O-Ring noir conforme à la norme EN 681-1.

Соответствует новым поправкам норматива EN 1254-2 Системы для газа и жидких углеводородов: желтая кольцевая прокладка в соответствии с нормативом EN 549 - EN 682. Водораспределительные системы (водопровод и отопление): черная кольцевая прокладка в соответствии с нормативом EN 681-1.

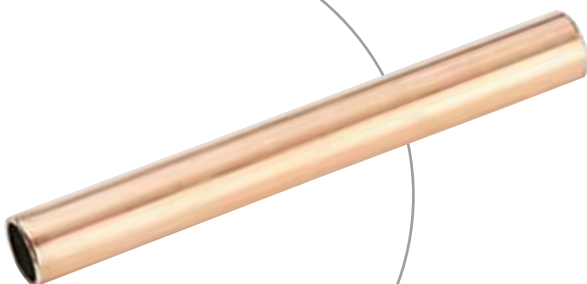
COPPER**R572**

Angle fittings with wall bearing.

Raccord équerre avec fixation murale.

Угловой фитинг с настенным креплением.



PRODUCT CODE	SIZE	■	□
R572Y112	1/2"x12	10	100
R572Y113	1/2"x14	10	100
R572Y114	1/2"x15	10	100
R572Y115	1/2"x16	10	100
R572Y116	1/2"x18	10	100

APPLICATIONS



INFO

In accordance with the updating of EN 1254-2 standard Gas installations and fluid hydrocarbons: yellow o-ring in accordance with EN 549 - EN 682 standard. Water distribution systems (drinking water and heating): black o-ring in accordance with EN 681-1 standard.

Conforme à la mise à jour de la norme EN 1254-2 Installation gaz et hydrocarbure liquide. Joint O-ring jaune conforme EN 549 - EN 682. Installation de distribution d'eau (eau chaude et froide sanitaire et chauffage): joint O-Ring noir conforme à la norme EN 681-1.

Соответствует новым поправкам норматива EN 1254-2 Системы для газа и жидких углеводородов: желтая кольцевая прокладка в соответствии с нормативом EN 549 - EN 82. Водораспределительные системы (водопровод и отопление): черная кольцевая прокладка в соответствии с нормативом EN 681-1.

COPPER

FITTINGS IRON-COPPER
 RACCORDS FILET UNIVERSEL - CUIVRE
 ФИТИНГИ ДЛЯ СОЕДИНЕНИЯ СТАЛЬНЫХ ТРУБ С МЕДНЫМИ
340FR

Straight fitting in 3 pieces, female-female connections, brass finish.

Nipple à souder.

Прямой нехромированный фитинг из 3 частей, соединения внутренние.



PRODUCT CODE	SIZE	□	▣
340FRY014	1/2"x15	25	250
340FRY015	1/2"x16	25	250
340FRY016	1/2"x18	25	250
340FRY021	3/4"x18	10	100
340FRY023	3/4"x22	10	100
340FRY027	1"x22	10	100
340FRY028	1"x28	10	100
340FRY035	1"1/4x35	5	50

APPLICATIONS

**98FR**

Bent fitting in 3 pieces, female connections, brass finish.

Coude in 3 pièces, mâle, à souder, laiton

Угловой нехромированный фитинг из 3 частей, соединения внутренние.



PRODUCT CODE	SIZE	□	▣
98FRY006	3/8"x15	25	250
98FRY013	1/2"x14	25	250
98FRY014	1/2"x15	25	250
98FRY015	1/2"x16	25	250
98FRY016	1/2"x18	25	100
98FRY021	3/4"x18	25	100
98FRY023	3/4"x22	25	100
98FRY027	1"x22	5	50
98FRY028	1"x28	5	50
98FRY035	1"1/4x35	1	-

APPLICATIONS

**341FR**

Straight fitting in 3 pieces, female-male connections, brass finish.

Raccord droit in 3 pièces, femelle-mâle, laiton.

Прямой нехромированный фитинг из 3 частей, соединения внутреннее и внешнее.



PRODUCT CODE	SIZE	□	▣
341FRY006	3/8"x15	25	250
341FRY013	1/2"x14	25	250
341FRY014	1/2"x15	25	250
341FRY015	1/2"x16	25	250
341FRY016	1/2"x18	25	250
341FRY021	3/4"x18	25	100
341FRY023	3/4"x22	25	100
341FRY027	1"x22	10	100
341FRY028	1"x28	10	100
341FRY035	1"1/4x35	5	50

APPLICATIONS

**92FR**

Bent fitting female-male connections, brass finish.

Coude à souder, femelle.

Угловой нехромированный фитинг, соединения внутреннее и внешнее.



PRODUCT CODE	SIZE	□	▣
92FRY013	1/2"x14	25	250
92FRY014	1/2"x15	25	250
92FRY015	1/2"x16	25	250
92FRY016	1/2"x18	25	250
92FRY021	3/4"x18	25	250
92FRY023	3/4"x22	0	-
92FRY035	1"1/4x35	1	-

APPLICATIONS

**90FR**

Bent fitting female connections brass finish.

Coude à souder, femelle.

Угловой нехромированный фитинг, соединения внутренние.



PRODUCT CODE	SIZE	□	▣
90FRY006	3/8"x15	25	250
90FRY013	1/2"x14	25	250
90FRY014	1/2"x15	25	250
90FRY015	1/2"x16	25	250
90FRY016	1/2"x18	25	250
90FRY020	3/4"x16	25	250
90FRY021	3/4"x18	25	250
90FRY023	3/4"x22	10	100
90FRY028	1"x28	10	100

APPLICATIONS

**96FR**

Bent fitting in 3 pieces, female connections, brass finish.

Coude in 3 pièces, femelle, à souder, laiton.

Угловой нехромированный фитинг из 3 частей, соединения внутренние.



PRODUCT CODE	SIZE	□	▣
96FRY014	1/2"x15	25	250
96FRY015	1/2"x16	25	250
96FRY016	1/2"x18	25	250
96FRY021	3/4"x18	25	100
96FRY023	3/4"x22	25	100
96FRY028	1"x28	5	50
96FRY035	1"1/4x35	1	-

APPLICATIONS

**471FR**

Solder end bent fitting with wall bearing, brass finish.

Coude à souder.

Угловой нехромированный фитинг под пайку с настенным креплением.



PRODUCT CODE	SIZE	□	▣
471FRY012	1/2"x12	1	250
471FRY013	1/2"x14	1	250
471FRY014	1/2"x15	1	250
471FRY015	1/2"x16	1	250

243FR

Straight fitting female-male connections, brass finish.



Raccord droit à souder.

Прямой нехромированный фитинг, соединения внутреннее и внешнее.

PRODUCT CODE	SIZE	■	□
243FRY013	1/2"x14	50	500
243FRY014	1/2"x15	50	500
243FRY015	1/2"x16	50	500
243FRY016	1/2"x18	50	500
243FRY020	3/4"x16	25	250
243FRY021	3/4"x18	25	250
243FRY023	3/4"x22	25	250
243FRY024	3/4"x28	10	100
243FRY027	1"x22	10	100
243FRY028	1"x28	10	100
243FRY034	1"1/4x28	10	100
243FRY035	1"1/4x35	10	100
243FRY042	1"1/2x42	5	50
243FRY054	2"x54	2	40

APPLICATIONS

**359FR**

Straight fitting female connections brass finish.



Raccord à souder.

Прямой нехромированный фитинг, соединения внутреннее.

PRODUCT CODE	SIZE	■	□
359FRY013	1/2"x14	1	250
359FRY014	1/2"x15	1	250
359FRY015	1/2"x16	1	250
359FRY016	1/2"x18	1	250
359FRY020	3/4"x16	1	250
359FRY021	3/4"x18	1	250
359FRY023	3/4"x22	1	250
359FRY024	3/4"x28	1	250
359FRY027	1"x22	1	100
359FRY028	1"x28	1	100
359FRY035	1"1/4x35	1	100

FITTINGS FOR IRON TUBE

RACCORDS AVEC FILET UNIVERSEL
ФИТИНГИ ДЛЯ СТАЛЬНЫХ ТРУБ

R18

Straight fitting in 3 pieces for iron tube.



Raccord union droit.

Проходной фитинг из 3 частей для стальной трубы.

brass finish - laiton - нехромированный

PRODUCT CODE	SIZE	■	□
R18Y002	3/8"	25	250
R18Y003	1/2"	25	250
R18Y004	3/4"	25	100
R18Y005	1"	25	100
R18Y006	1"1/4	5	50
R18Y007	1"1/2	2	20
R18Y008	2"	2	10

chrome plated - chromé - хромированный

PRODUCT CODE	SIZE	■	□
R18X002	3/8"	25	250
R18X003	1/2"	25	250
R18X004	3/4"	25	100
R18X005	1"	25	100
R18X006	1"1/4	5	50
R18X007	1"1/2	2	20
R18X008	2"	2	10

R189

Nipple, brass finish.



Nipple laiton.

Ниппель нехромированный.

PRODUCT CODE	SIZE	■	□
R189Y002	3/8"	100	1.000
R189Y003	1/2"	50	500
R189Y004	3/4"	25	250
R189Y005	1"	25	250
R189Y006	1"1/4	10	100
R189Y007	1"1/2	5	50

R19

Angle fitting in 3 pieces for iron tube.



Raccord union équerre.

Угловой фитинг из 3 частей для стальной трубы.

brass finish - laiton - нехромированный

PRODUCT CODE	SIZE	■	□
R19Y002	3/8"	25	250
R19Y003	1/2"	25	100
R19Y004	3/4"	25	100
R19Y005	1"	25	50
R19Y006	1"1/4	2	20
R19Y007	1"1/2	2	20
R19Y008	2"	2	10

chrome plated - chromé - хромированный

PRODUCT CODE	SIZE	■	□
R19X002	3/8"	25	250
R19X003	1/2"	25	100
R19X004	3/4"	25	100
R19X005	1"	25	50
R19X006	1"1/4	2	20
R19X007	1"1/2	2	20
R19X008	2"	2	10

R18SP

Straight fitting in 3 pieces for iron tube, flat seat.



Raccord trois pièces pour tube acier avec joint plat.

Прямой фитинг разборный, из 3 частей, для стальной трубы.

PRODUCT CODE	SIZE	■	□
R18SPY005	1"	25	100
R18SPY006	1"1/4	5	50
R18SPY007	1"1/2	2	20
R18SPY008	2"	2	10

R20

3 pieces straight fitting, male-male flat seat, brass finish.



Raccord droit trois pièces mâle mâle, joint plat, non chromé.

Прямой фитинг разборный, из 3 частей, с наружной-наружной резьбой, не хромированный.

PRODUCT CODE	SIZE	■	□
R20Y004	3/4"x3/4"	25	100

R189D

Nipple, self-sealing, brass finish.



Nipple auto-étanche, laiton.

Ниппель нехромированный с герметичной прокладкой.

PRODUCT CODE	SIZE	■	□
R189DY003	1/2"	50	500
R189DY004	3/4"	25	250
R189DY005	1"	25	250
R189DY006	1"1/4	10	100

COPPER

FITTINGS WITH METAL SLEEVE
 RACCORDS AVEC BICÔNE MÉTALLIQUE
 ФИТИНГИ С МЕТАЛЛИЧЕСКИМ СУХАРЕМ
310

Straight fitting with metallic chamfered ring and copper connections.

Raccord droit cuivre cuivre.

Прямая соединительная муфта для медных труб.



PRODUCT CODE	SIZE	□	▣
310Y004	15x15	25	250
310Y010	18x18	10	100
310Y006	22x22	10	100
310Y007	28x28	10	100

APPLICATIONS

INFO

In compliance with EN 1254-2 standard.

315

Elbow with metallic chamfered ring and copper connections.

Coude cuivre cuivre.

Угловое соединение для медных труб.



PRODUCT CODE	SIZE	□	▣
315Y001	15x15	25	250
315Y010	18x18	10	100
315Y003	22x22	10	100
315Y004	28x28	5	50

Technical communication 0293EN

APPLICATIONS

INFO

In compliance with EN 1254-2 standard.

311

Straight fitting with metallic chamfered ring and copper connection and male threaded connection.

Raccord droit male bi-cône pour tube cuivre.

Переходное соединение с внешней резьбой от железной трубы к медной.



Technical communication 0293EN

PRODUCT CODE	SIZE	□	▣
311Y001	1/2"x15	25	250
311Y010	1/2Mx18	25	250
311Y002	3/4"x15	25	250
311Y011	3/4Mx18	25	250
311Y003	3/4"x22	10	100
311Y004	1"x22	10	100
311Y005	1"x28	10	100

APPLICATIONS

INFO

In compliance with EN 1254-2 standard.

317

Elbow with metallic chamfered ring, with copper pipe connection and female threaded connection.

Raccord équerre avec bicône métallique, avec raccordement pour tube cuivre et filet universel femelle.

Угловой фитинг с металлическим сухарем, с соединением для медной трубы и соединением с внутренней резьбой.



PRODUCT CODE	SIZE	□	▣
317X001	1/2"x15*	25	250
317X002	3/4"x22*	10	100
317X003	1"x22	10	100
317X004	1"x28	5	50

APPLICATIONS

INFO

In compliance with EN 1254-2 standard.

312

Straight fitting with metallic chamfered ring and copper connection and female threaded connection.

Raccord droit femelle bi-cône pour tube cuivre.

Переходное соединение с внутренней резьбой от железной трубы к медной.



Technical communication 0293EN

PRODUCT CODE	SIZE	□	▣
312Y001	1/2"x15	25	250
312Y010	1/2Fx18	25	250
312Y002	3/4"x15	25	250
312Y011	3/4Fx18	10	100
312Y003	3/4"x22	10	100
312Y004	1"x22	10	100
312Y005	1"x28	10	100

APPLICATIONS

INFO

In compliance with EN 1254-2 standard.

318

T fitting with metallic chamfered ring and connections for copper pipe.

Té avec raccord bi-cône pour tube cuivre.

Тройник для медных труб.



Technical communication 0293EN

PRODUCT CODE	SIZE	□	▣
318Y001	15x15x15	10	100
318Y010	18x18x18	10	100
318Y006	22x22x22	5	50
318Y014	28x28x28	5	50

APPLICATIONS

INFO

In compliance with EN 1254-2 standard.